



# **DS-KD7003EY-IME2 Module Door Station**

**User Manual**

## Legal Information

### About this Document

- This Document includes instructions for using and managing the Product. Pictures, charts, images and all other information hereinafter are for description and explanation only.
- The information contained in the Document is subject to change, without notice, due to firmware updates or other reasons. Please find the latest version of the Document at the Hikvision website ( <https://www.hikvision.com> ). Unless otherwise agreed, Hangzhou Hikvision Digital Technology Co., Ltd. or its affiliates (hereinafter referred to as "Hikvision") makes no warranties, express or implied.
- Please use the Document with the guidance and assistance of professionals trained in supporting the Product.

### About this Product

This product can only enjoy the after-sales service support in the country or region where the purchase is made.

### Acknowledgment of Intellectual Property Rights

- Hikvision owns the copyrights and/or patents related to the technology embodied in the Products described in this Document, which may include licenses obtained from third parties.
- Any part of the Document, including text, pictures, graphics, etc., belongs to Hikvision. No part of this Document may be excerpted, copied, translated, or modified in whole or in part by any means without written permission.
- **HIKVISION** and other Hikvision's trademarks and logos are the properties of Hikvision in various jurisdictions.
- Other trademarks and logos mentioned are the properties of their respective owners.

### LEGAL DISCLAIMER

- TO THE MAXIMUM EXTENT PERMITTED BY APPLICABLE LAW, THIS DOCUMENT AND THE PRODUCT DESCRIBED, WITH ITS HARDWARE, SOFTWARE AND FIRMWARE, ARE PROVIDED "AS IS" AND "WITH ALL FAULTS AND ERRORS". HIKVISION MAKES NO WARRANTIES, EXPRESS OR IMPLIED, INCLUDING WITHOUT LIMITATION, MERCHANTABILITY, SATISFACTORY QUALITY, OR FITNESS FOR A PARTICULAR PURPOSE. THE USE OF THE PRODUCT BY YOU IS AT YOUR OWN RISK. IN NO EVENT WILL HIKVISION BE LIABLE TO YOU FOR ANY SPECIAL, CONSEQUENTIAL, INCIDENTAL, OR INDIRECT DAMAGES, INCLUDING, AMONG OTHERS, DAMAGES FOR LOSS OF BUSINESS PROFITS, BUSINESS INTERRUPTION, OR LOSS OF DATA, CORRUPTION OF SYSTEMS, OR LOSS OF DOCUMENTATION, WHETHER BASED ON BREACH OF CONTRACT, TORT (INCLUDING NEGLIGENCE), PRODUCT LIABILITY, OR OTHERWISE, IN CONNECTION WITH THE USE OF THE



PRODUCT, EVEN IF HIKVISION HAS BEEN ADVISED OF THE POSSIBILITY OF SUCH DAMAGES OR LOSS.

- YOU ACKNOWLEDGE THAT THE NATURE OF THE INTERNET PROVIDES FOR INHERENT SECURITY RISKS, AND HIKVISION SHALL NOT TAKE ANY RESPONSIBILITIES FOR ABNORMAL OPERATION, PRIVACY LEAKAGE OR OTHER DAMAGES RESULTING FROM CYBER-ATTACK, HACKER ATTACK, VIRUS INFECTION, OR OTHER INTERNET SECURITY RISKS; HOWEVER, HIKVISION WILL PROVIDE TIMELY TECHNICAL SUPPORT IF REQUIRED.
- YOU AGREE TO USE THIS PRODUCT IN COMPLIANCE WITH ALL APPLICABLE LAWS, AND YOU ARE SOLELY RESPONSIBLE FOR ENSURING THAT YOUR USE CONFORMS TO THE APPLICABLE LAW. ESPECIALLY, YOU ARE RESPONSIBLE, FOR USING THIS PRODUCT IN A MANNER THAT DOES NOT INFRINGE ON THE RIGHTS OF THIRD PARTIES, INCLUDING WITHOUT LIMITATION, RIGHTS OF PUBLICITY, INTELLECTUAL PROPERTY RIGHTS, OR DATA PROTECTION AND OTHER PRIVACY RIGHTS. YOU SHALL NOT USE THIS PRODUCT FOR ANY PROHIBITED END-USES, INCLUDING THE DEVELOPMENT OR PRODUCTION OF WEAPONS OF MASS DESTRUCTION, THE DEVELOPMENT OR PRODUCTION OF CHEMICAL OR BIOLOGICAL WEAPONS, ANY ACTIVITIES IN THE CONTEXT RELATED TO ANY NUCLEAR EXPLOSIVE OR UNSAFE NUCLEAR FUEL-CYCLE, OR IN SUPPORT OF HUMAN RIGHTS ABUSES.
- IN THE EVENT OF ANY CONFLICTS BETWEEN THIS DOCUMENT AND THE APPLICABLE LAW, THE LATTER PREVAILS.

**© Hangzhou Hikvision Digital Technology Co., Ltd. All rights reserved.**

## Symbol Conventions

The symbols that may be found in this document are defined as follows.

Symbol	Description
 <b>Danger</b>	Indicates a hazardous situation which, if not avoided, will or could result in death or serious injury.
 <b>Caution</b>	Indicates a potentially hazardous situation which, if not avoided, could result in equipment damage, data loss, performance degradation, or unexpected results.
 <b>Note</b>	Provides additional information to emphasize or supplement important points of the main text.

## Regulatory Information

### EU Conformity Statement



This product and - if applicable - the supplied accessories too are marked with "CE" and comply therefore with the applicable harmonized European standards listed under the EMC Directive 2014/30/EU, the RoHS Directive 2011/65/EU



2012/19/EU (WEEE directive): Products marked with this symbol cannot be disposed of as unsorted municipal waste in the European Union. For proper recycling, return this product to your local supplier upon the purchase of equivalent new equipment, or dispose of it at designated collection points. For more information see: [www.recyclethis.info](http://www.recyclethis.info)



2006/66/EC (battery directive): This product contains a battery that cannot be disposed of as unsorted municipal waste in the European Union. See the product documentation for specific battery information. The battery is marked with this symbol, which may include lettering to indicate cadmium (Cd), lead (Pb), or mercury (Hg). For proper recycling, return the battery to your supplier or to a designated collection point. For more information see: [www.recyclethis.info](http://www.recyclethis.info)

### Industry Canada ICES-003 Compliance

This device meets the CAN ICES-3 (B)/NMB-3(B) standards requirements.

This device complies with Industry Canada licence-exempt RSS standard(s). Operation is subject to the following two conditions:

1. this device may not cause interference, and
2. this device must accept any interference, including interference that may cause undesired operation of the device.

Le présent appareil est conforme aux CNR d'Industrie Canada applicables aux appareils radioexempts de licence. L'exploitation est autorisée aux deux conditions suivantes :

1. l'appareil ne doit pas produire de brouillage, et
2. l'utilisateur de l'appareil doit accepter tout brouillage radioélectrique subi, même si le brouillage est susceptible d'en compromettre le fonctionnement.

Under Industry Canada regulations, this radio transmitter may only operate using an antenna of a type and maximum (or lesser) gain approved for the transmitter by Industry Canada. To reduce potential radio interference to other users, the antenna type and its gain should be so chosen that the equivalent isotropically radiated power (e.i.r.p.) is not more than that necessary for successful communication.

Conformément à la réglementation d'Industrie Canada, le présent émetteur radio peut fonctionner avec une antenne d'un type et d'un gain maximal (ou inférieur) approuvé pour l'émetteur par Industrie Canada. Dans le but de réduire les risques de brouillage radioélectrique à l'intention des autres utilisateurs, il faut choisir le type d'antenne et son gain de sorte que la puissance isotrope rayonnée équivalente (p.i.r.e.) ne dépasse pas l'intensité nécessaire à l'établissement d'une communication satisfaisante.

This equipment should be installed and operated with a minimum distance 20cm between the radiator and your body.

Cet équipement doit être installé et utilisé à une distance minimale de 20 cm entre le radiateur et votre corps.

## About this Manual

Get the manual and related software from or the official website (<http://www.hikvision.com>).

Product	Model
Door Station	DS-KD7003EY-IME2

Scan the QR code to get the User Manual for detailed information.



# Contents

<b>Chapter 1 Appearance</b> .....	<b>1</b>
<b>Chapter 2 Terminal and Wiring</b> .....	<b>3</b>
2.1 Terminal Description .....	3
<b>Chapter 3 Installation</b> .....	<b>5</b>
3.1 One-Module Installation .....	6
3.1.1 One-Module Surface Mounting .....	6
3.1.2 One-Module Flush Mounting .....	12
3.2 Two-Module Installation .....	17
3.2.1 Two-Module Surface Mounting .....	17
3.2.2 Two-Module Flush Mounting .....	23
3.3 Three-Module Installation .....	28
3.3.1 Three-Module Surface Mounting .....	28
3.3.2 Three-Module Flush Mounting .....	35
<b>Chapter 4 Topology</b> .....	<b>40</b>
<b>Chapter 5 Cable and Transmission Distance</b> .....	<b>45</b>
<b>Chapter 6 Typical Application and Flow</b> .....	<b>46</b>
<b>Chapter 7 Set Device Rotary DIP Switch</b> .....	<b>47</b>
<b>Chapter 8 Call Indoor Station from Door Station</b> .....	<b>50</b>
<b>Chapter 9 Unlock Door</b> .....	<b>51</b>
<b>Chapter 10 Enable AP Mode</b> .....	<b>52</b>
10.1 Enable AP Mode on Device .....	52
10.2 Enable AP Mode on PC Web .....	52
10.3 FAQ of AP Mode .....	52
<b>Chapter 11 Login Web Browser</b> .....	<b>55</b>
<b>Chapter 12 Forgot Password</b> .....	<b>56</b>
12.1 Forget Password via Mobile Web .....	56

12.2 Forget Password via PC Web .....	56
<b>Chapter 13 Overview .....</b>	<b>57</b>
13.1 Overview on Mobile Web .....	57
13.2 Overview on PC Web .....	57
<b>Chapter 14 Person Management .....</b>	<b>59</b>
14.1 Person Management on Mobile Web .....	59
14.2 Person Management on PC Web .....	60
<b>Chapter 15 Device Management .....</b>	<b>62</b>
15.1 View Room No. Details on Mobile Web .....	62
15.2 Device Management on PC Web .....	62
<b>Chapter 16 View Device Information .....</b>	<b>63</b>
16.1 View Device Information on Mobile Web .....	63
16.2 View Device Information on PC Web .....	63
<b>Chapter 17 Time Settings .....</b>	<b>64</b>
17.1 Set Time on Mobile Web .....	64
17.2 Set DST on Mobile Web .....	64
17.3 Set Time on PC Web .....	65
17.4 Set DST on PC Web .....	65
<b>Chapter 18 Audio Settings .....</b>	<b>66</b>
18.1 Set Audio Parameters on Mobile Web .....	66
18.2 Set Audio Parameters on PC Web .....	66
<b>Chapter 19 Image Settings .....</b>	<b>67</b>
19.1 Set Image Parameters on Mobile Web .....	67
19.2 Set Image Parameters on PC Web .....	67
19.3 Set OSD (On-Screen Display) on PC Web .....	68
19.4 Crop Target on PC Web .....	68
<b>Chapter 20 Motion Detection Settings .....</b>	<b>70</b>
20.1 Set Motion Detection on Mobile Web .....	70

20.2 Set Motion Detection on PC Web .....	70
<b>Chapter 21 Access Control Settings .....</b>	<b>71</b>
21.1 Set Door Parameters on Mobile Web .....	71
21.2 Set Public Password on Mobile Web .....	71
21.3 Set I/O Parameters on Mobile Web .....	71
21.4 Set Door Parameters on PC Web .....	72
21.5 Set Public Password on PC Web .....	72
21.6 Set I/O Parameters on PC Web .....	72
<b>Chapter 22 Video Intercom Settings .....</b>	<b>74</b>
22.1 Set Call Parameters on Mobile Web .....	74
22.2 Press Button to Call on Mobile Web .....	74
22.3 Set Sub Module on Mobile Web .....	75
22.4 Set Ringtone on PC Web .....	75
22.5 Set Call Parameters on PC Web .....	75
22.6 Press Button to Call on PC Web .....	75
22.7 Set Sub Module on PC Web .....	76
<b>Chapter 23 Card Settings .....</b>	<b>77</b>
23.1 Set Card Security .....	77
23.2 Set Card Security on PC Web .....	77
<b>Chapter 24 Set Fingerprint Security Level .....</b>	<b>78</b>
24.1 Set Fingerprint Security Level on PC Web .....	78
24.2 Set Fingerprint Security Level on Mobile Web .....	78
<b>Chapter 25 Upgrade and Maintenance .....</b>	<b>79</b>
25.1 Upgrade and Maintenance on Mobile Web .....	79
25.2 Upgrade and Maintenance on PC Web .....	79
<b>Chapter 26 Change Activation/Admin Password .....</b>	<b>81</b>
26.1 Change Administrator's Password on Mobile Web .....	81
26.2 Change Administrator's Password on PC Web .....	81

<b>Chapter 27 Account Security Settings .....</b>	<b>83</b>
27.1 Set Account Security on Mobile Web .....	83
27.2 Set Account Security on PC Web .....	83
<b>Chapter 28 View Device Arming/Disarming Information on PC Web .....</b>	<b>84</b>
<b>Chapter 29 View Online Users on PC Web .....</b>	<b>85</b>
<b>Chapter 30 Set Notice Publication on PC Web .....</b>	<b>86</b>
<b>Chapter 31 Device Debugging on PC Web .....</b>	<b>87</b>
<b>Chapter 32 View Online Document .....</b>	<b>88</b>
32.1 View Online Document on Mobile Web .....	88
32.2 View Online Document on PC Web .....	88
<b>Chapter 33 View Open Source Software License .....</b>	<b>89</b>
33.1 View Open Source Software License on Mobile Web .....	89
33.2 View Open Source Software License on PC Web .....	89
<b>Chapter 34 Quick Operation via Web Browser .....</b>	<b>90</b>
34.1 Change Password Type .....	90
34.2 Select Language .....	90
34.3 Time Settings .....	90
34.4 Administrator Settings .....	91
34.5 Link Video Intercom Devices .....	91

## Chapter 1 Appearance

### Main Unit

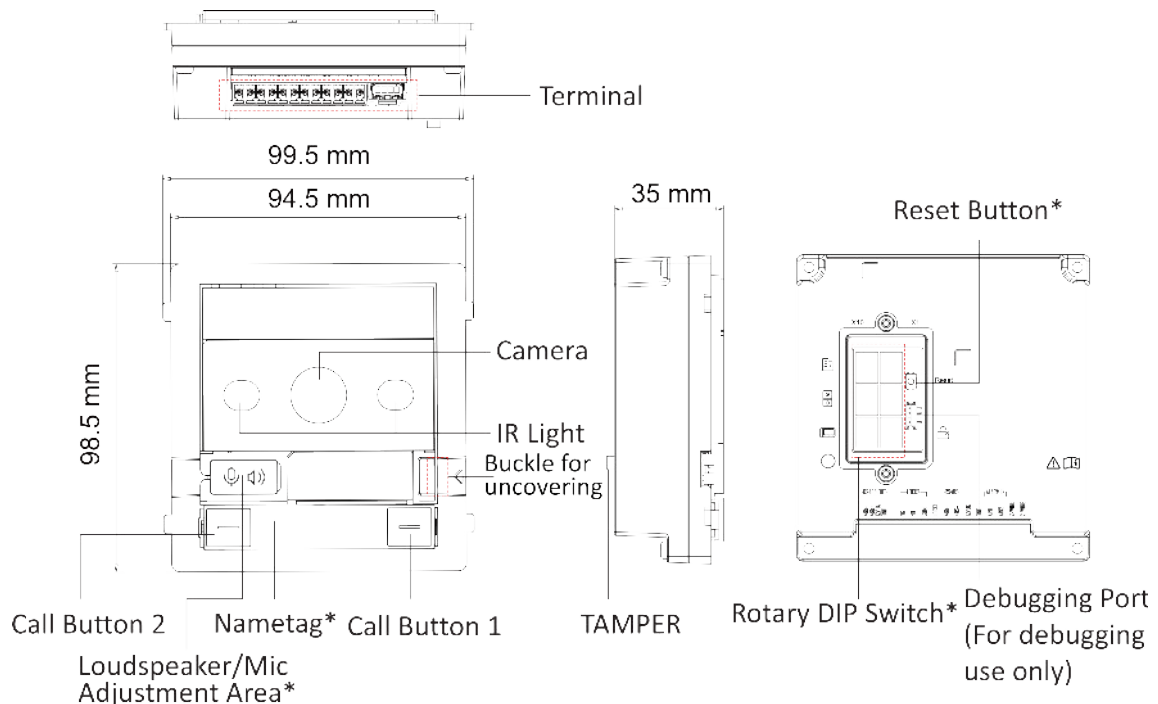

Figure 1-1 Main Unit Appearance

### Note

- Loudspeaker/Mic Adjustment Area: Press the buckle and push the tag to the left to uncover the metal cover. Remove the dust-proof plug and use drill to adjust the volume of loudspeaker and the microphone. (The first is for the loudspeaker and the second is for the Mic.)
- Reset Button : Reset AP Mode Password: Hold the button for 5 s.
- Restore Factory Settings: Hold the button for 10 s.
- DIP Switch: Set the door station's DIP switch address and video intercom system can find the door station according to the address.
- Call Button: By default, press call button 1 to call Room No.1 and press call button 2 to call Room No.2.
- Name Tag : Remove the metal cover and you can stick a name tag according to your preference.  
Name tag 1: Two call buttons Left: Press once to call a specific room No. Hold the button for 10 s to enable the device AP mode. Right: Press once to call a specific room No. Hold the button for 10 s to synchronize the device parameters to the web, including contacts, language, device time, etc.  
Name tag 2: one call button Press once to call a specific room No.

Name tag 3: No call button

---

## Chapter 2 Terminal and Wiring

### 2.1 Terminal Description

#### Terminals

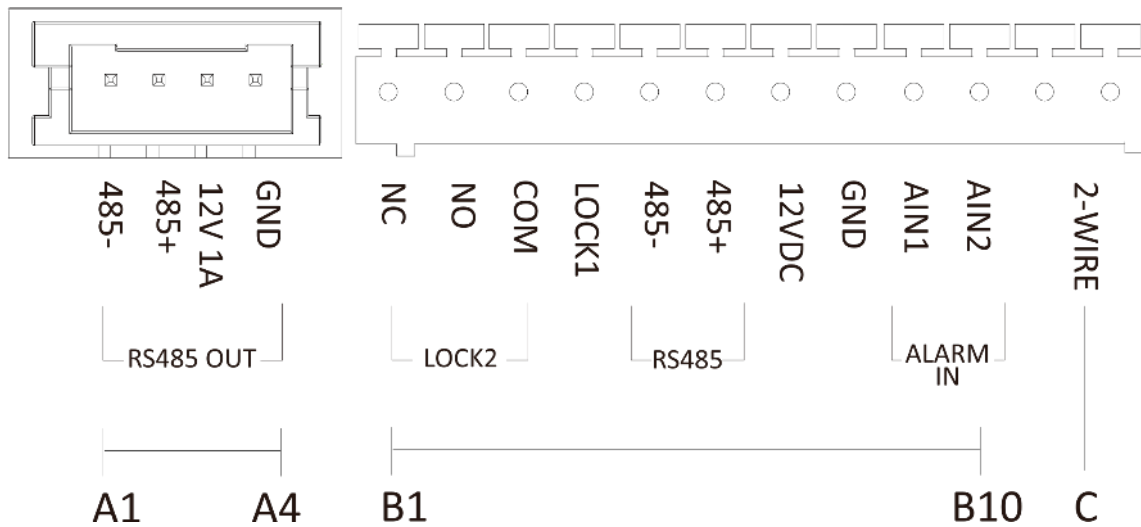

Figure 2-1 Main Unit Terminals

Table 2-1 Descriptions of Terminals and Interfaces

No.	Interface	Description
A1	485-	Module-connecting Interface
A2	485+	
A3	12V 1A	
A4	GND	
B1	NC	Door Lock Relay Output (NC)
B2	NO	Door Lock Relay Output (NO)
B3	COM	Common Interface
B4	LOCK1	Door Lock Interface
B5	485-	Reserved
B6	485+	
B7	12VDC	12 V power input

No.	Interface	Description
B8	GND	Grounding
B9	AIN1	Exit Button 1 (for unlocking door 1)
B10	AIN2	Exit Button 2 (for unlocking door 2)
C	2-WIRE Interface	2-Wire Interface

**Wiring**

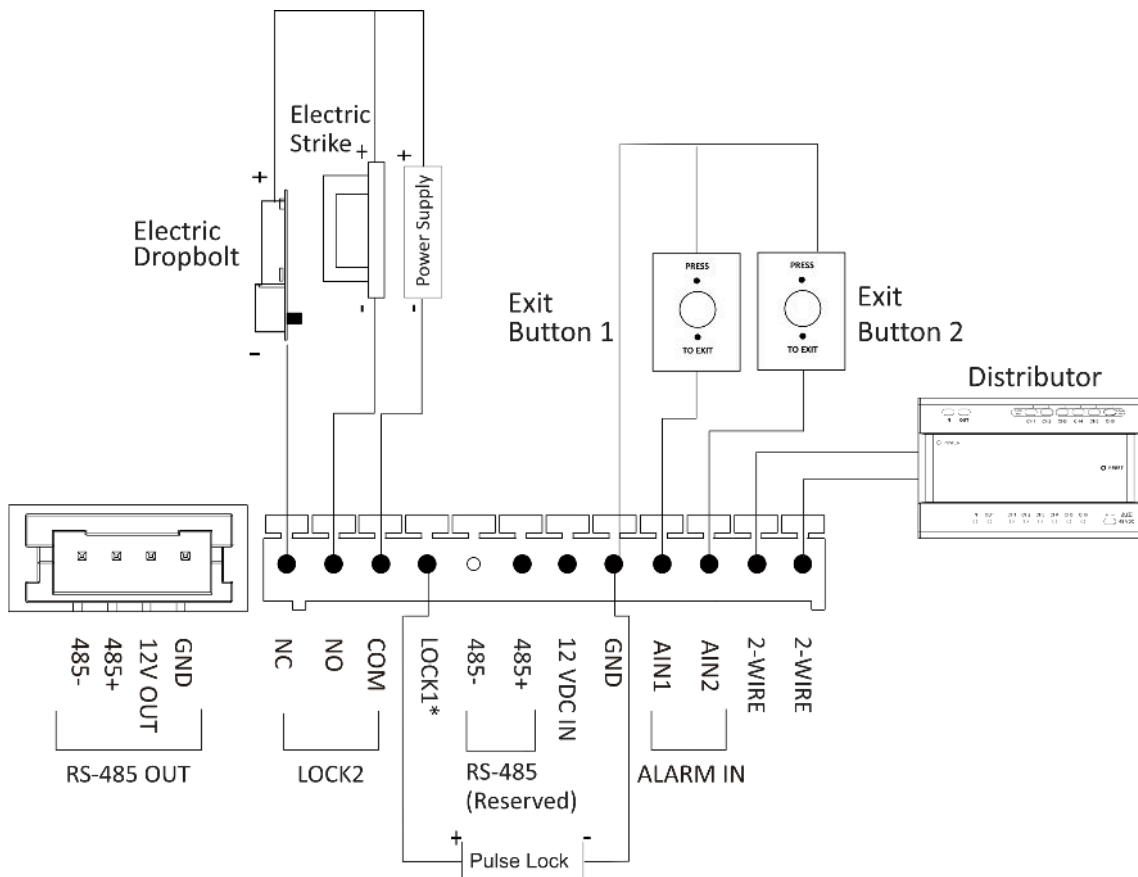

**Figure 2-2 Wiring of Door Station**

**Note**

- LOCK 1 is an 20 V/4 A impulse output with 300 mA holding current.
- The Exit Button 1 is for unlocking door 1; The Exit Button 2 is for unlocking door 2.

## Chapter 3 Installation

---

 **Note**

- Sub module must work along with the main unit.
  - Sub modules share the same approach of the installation. The sub modules in installation images are for reference only.
  - Make sure the device in the package is in good condition and all the assembly parts are included.
  - Set the sub module address before start the installation steps.
  - Make sure the place for surface mounting is flat.
  - Make sure all the related equipment is power-off during the installation.
  - Tools that you need to prepare for installation:  
Drill (∅6), cross screwdriver (PH1\*150 mm), and gradienter.
-

### 3.1 One-Module Installation

#### 3.1.1 One-Module Surface Mounting

##### Before You Start

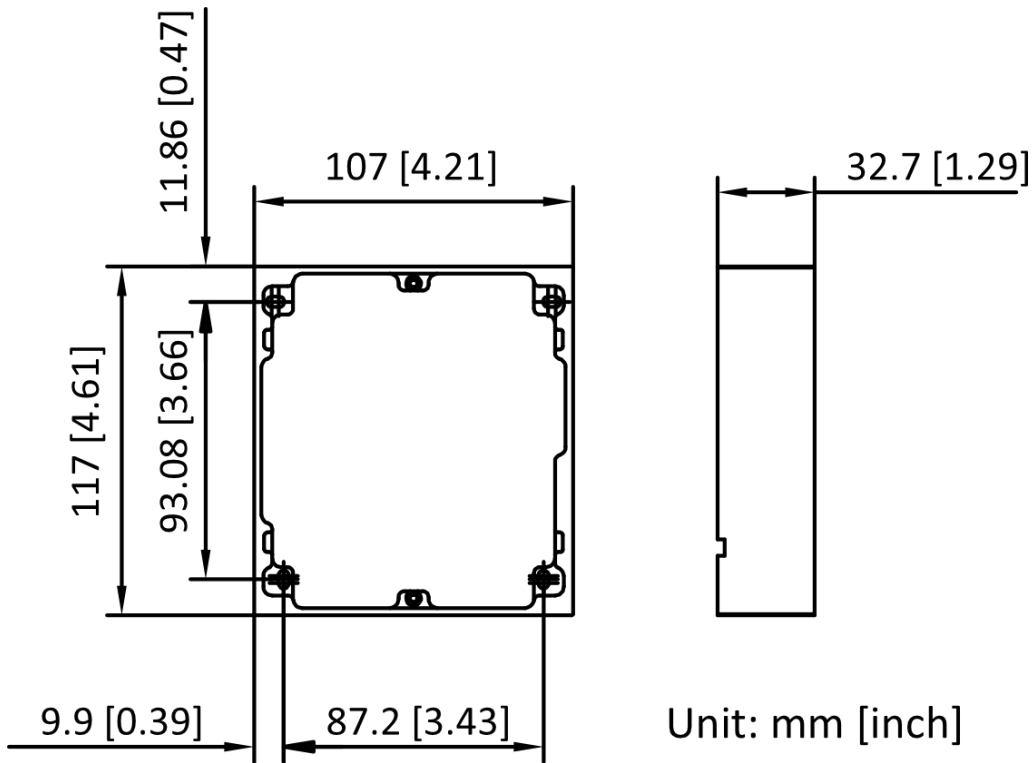

Figure 3-1 Mounting Frame

---

##### Note

- The suggested depth of the installation hole is 33 mm.
- The dimensions above are for reference only. The actual size can be slightly different from the theoretical dimension.

---

##### Steps

1. Stick the mounting sticker to the wall. The suggested length of cables left outside is 270 mm.

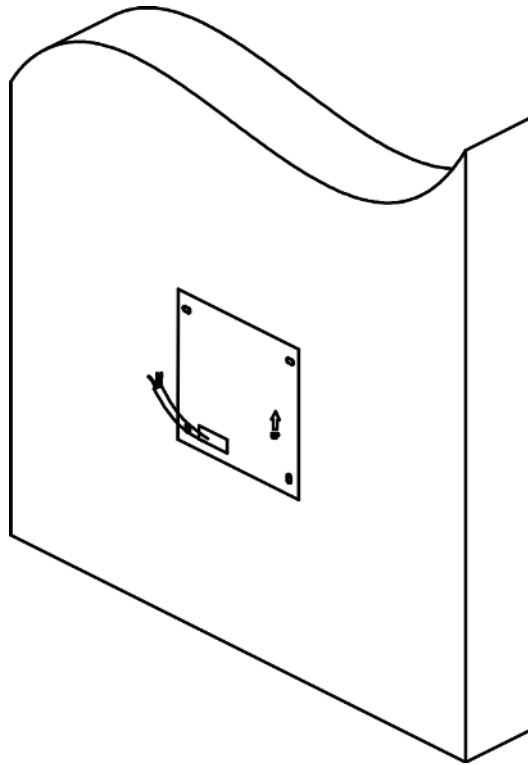

**Figure 3-2 Stick the Sticker**

2. Drill 4 holes of 25 mm deep according to the marks on the sticker and insert the expansion sleeves into the screw holes. Remove the mounting sticker and fix the mounting frame to the wall with 4 expansion bolts.

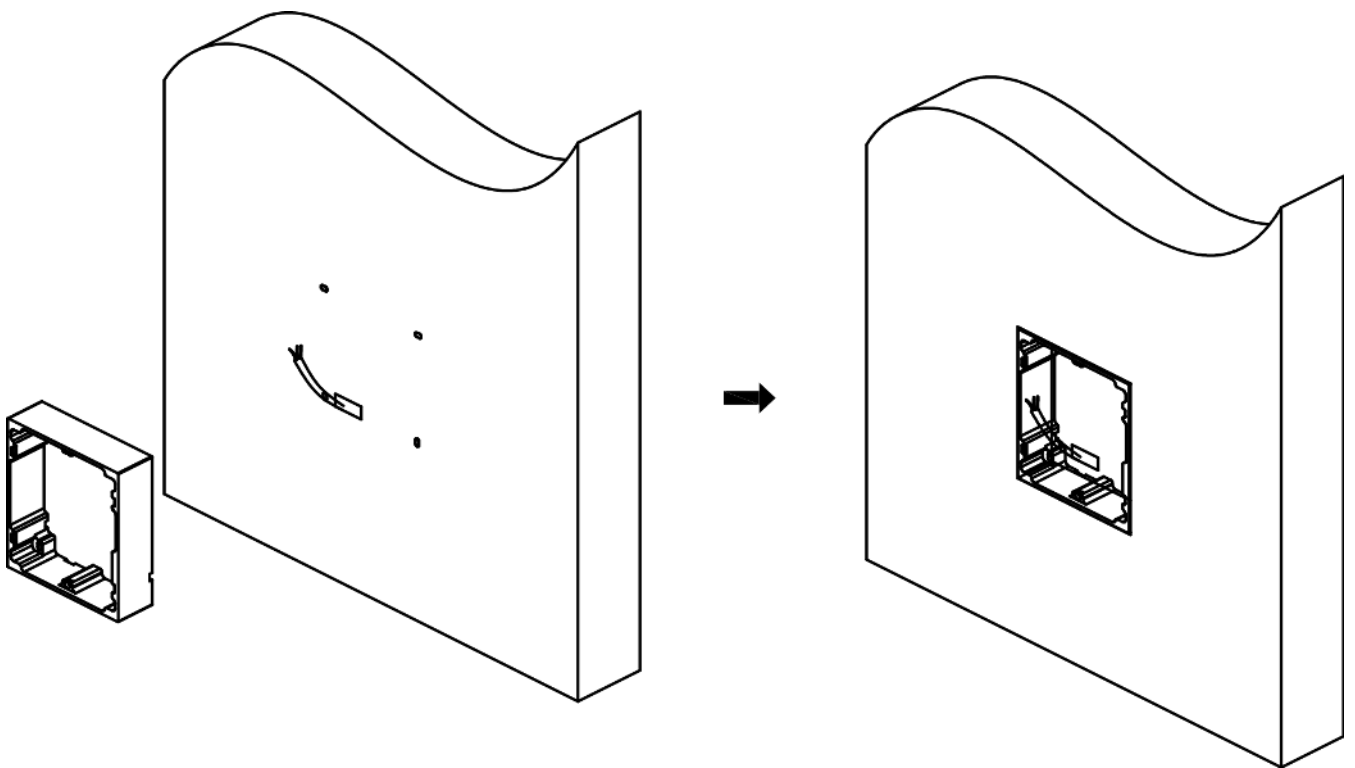

**Figure 3-3 Fix the Mounting Frame**

3. Thread the module-connecting line across the thread holes of the frame. Insert the modules into the frame after wiring.

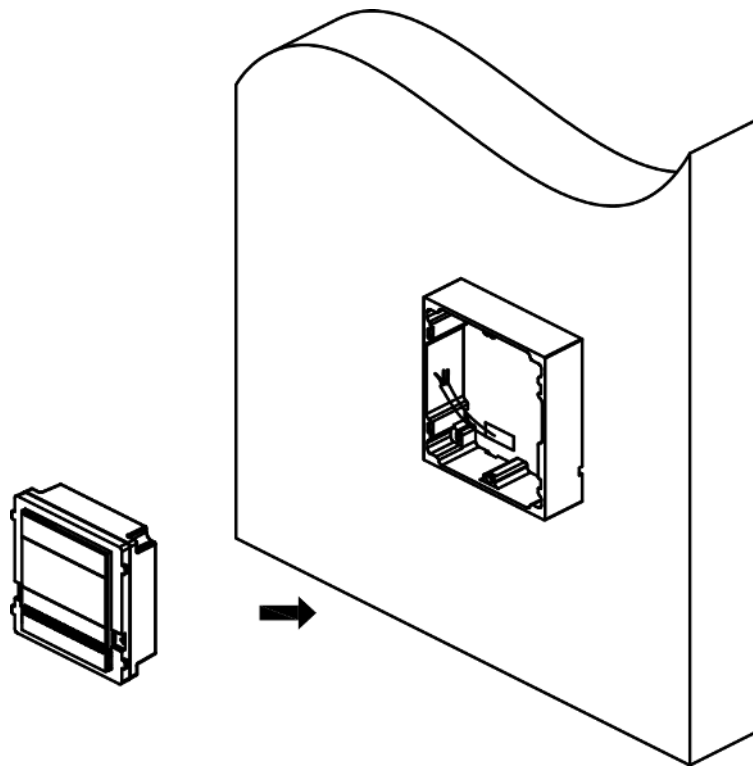

**Figure 3-4 Fix Modules to the Frame**

4. Apply silicone sealant among the cable wiring area to keep the raindrop from entering.

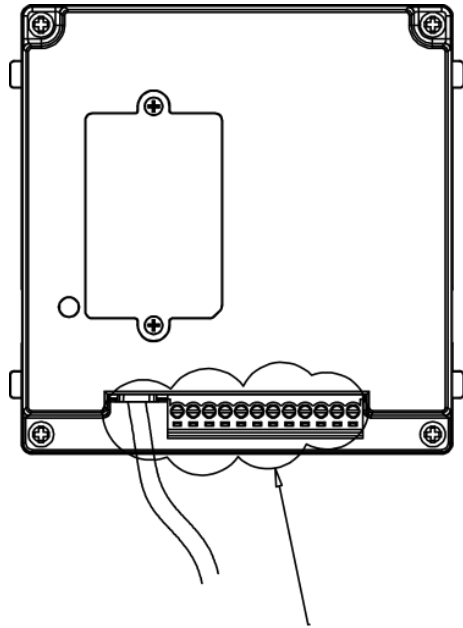

Apply silicone sealant among the cable wiring area to keep the raindrop from entering.

**Figure 3-5 Apply Silicone Sealant**

5. Use the hexagon wrench in the package to fix the cover onto the frame.

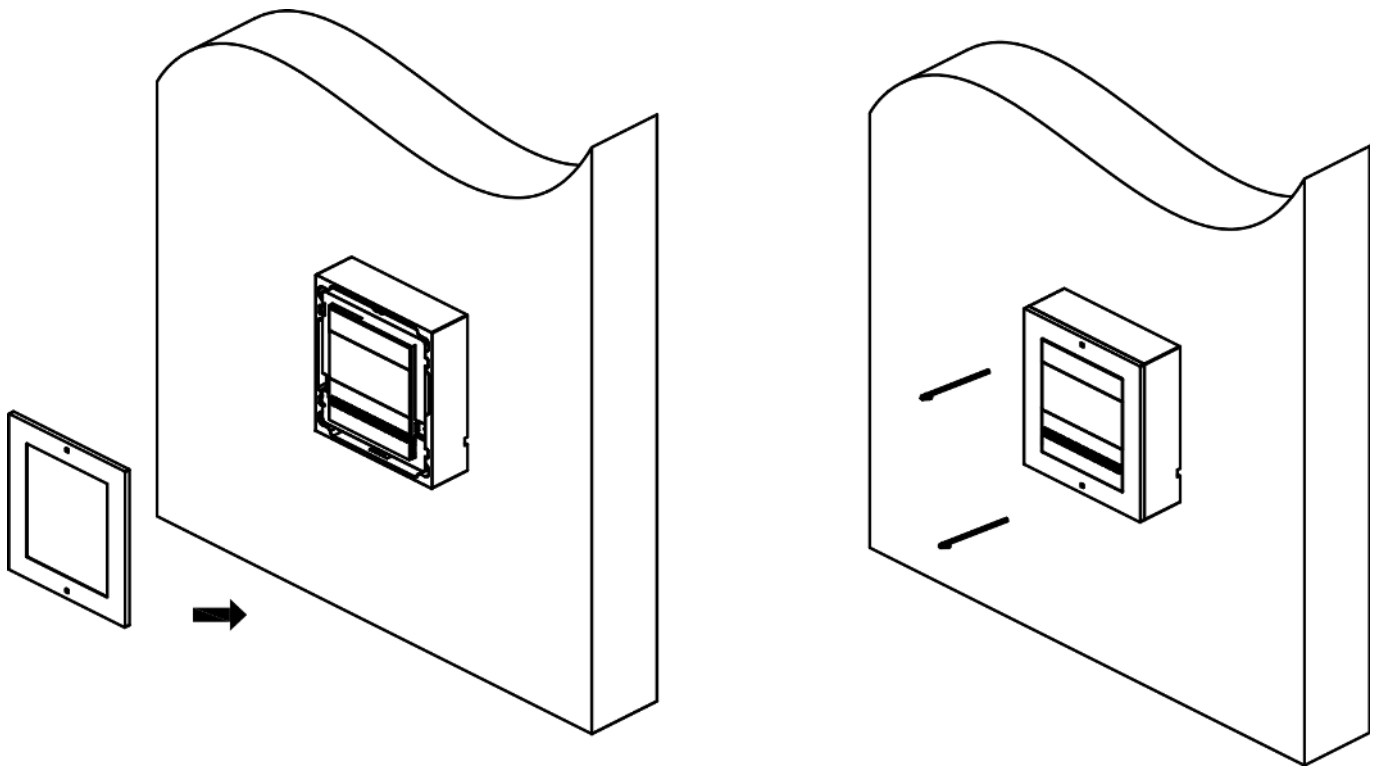

Figure 3-6 Fix the Cover

### 3.1.2 One-Module Flush Mounting

#### Before You Start

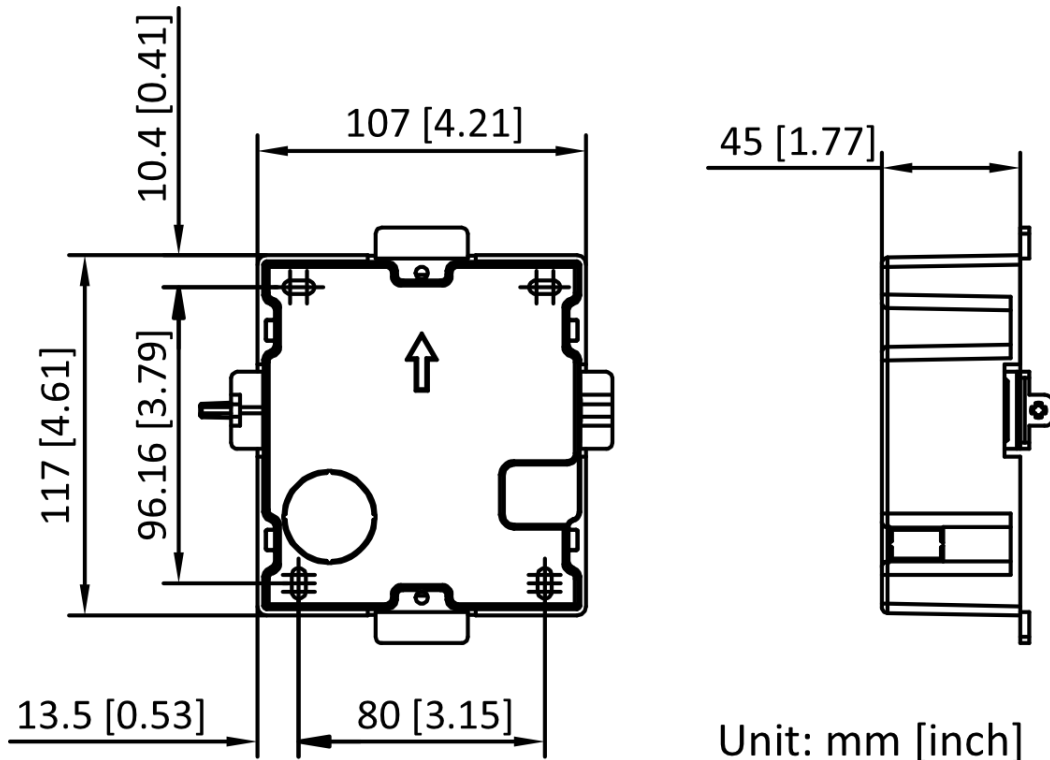

Figure 3-7 Mounting Box

#### Note

The dimensions above are for reference only. The actual size can be slightly different from the theoretical dimension.

#### Steps

1. Stick the mounting sticker to the wall and cave the installation hole according to the sticker. Pull the cable out. Stick the mounting sticker to the installation hole and drill 4 holes of 25 mm deep according to the marks on the sticker and insert the expansion sleeves into the screw holes.

#### Note

- The suggested depth of the hole is 44.5 mm.
- The suggested length of cables left outside is 270 mm.

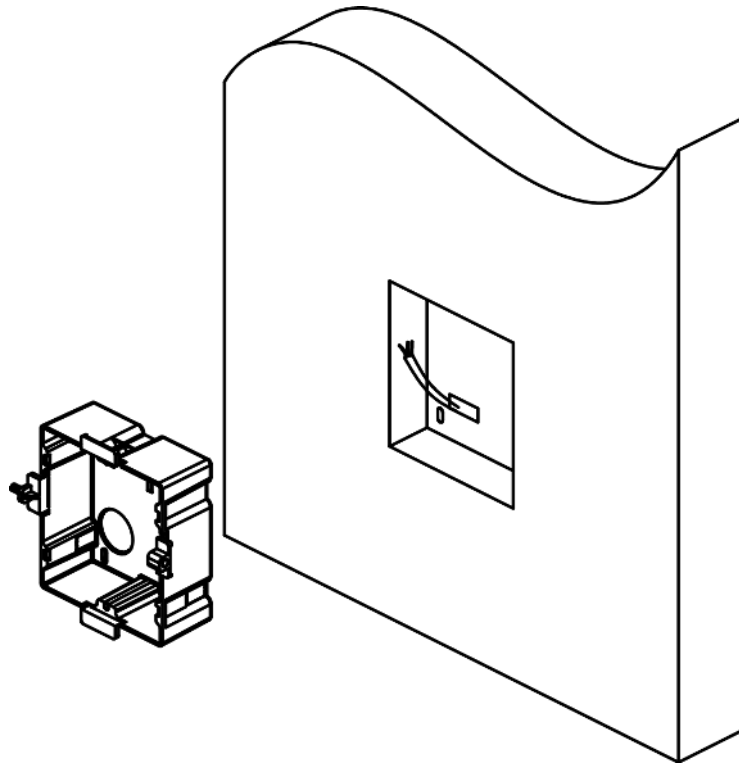

**Figure 3-8 Drill the Installation Hole**

2. Fix the mounting box to the installation with 4 expansion bolts. Remove the positioning piece of the mounting box.

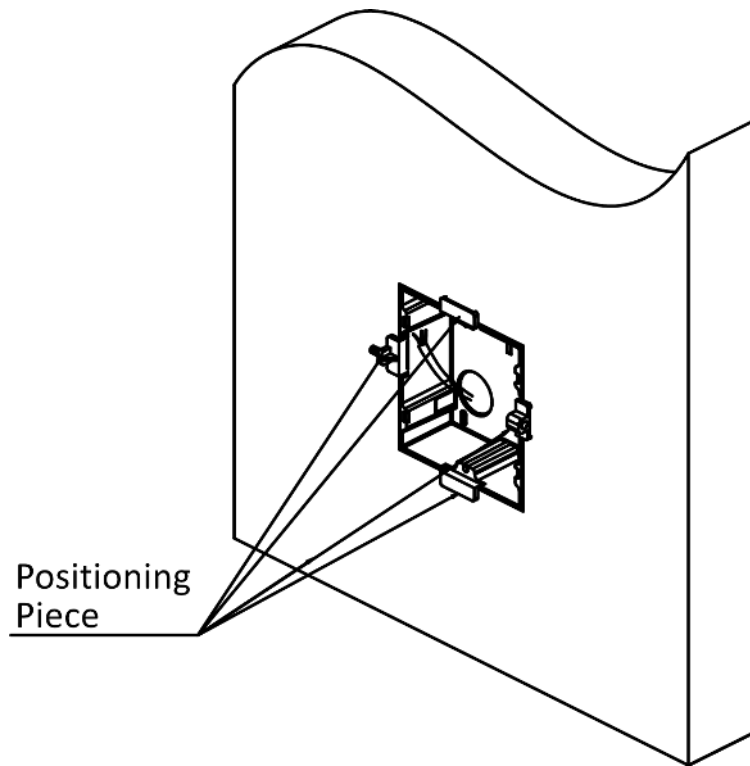

**Figure 3-9 Fix the Mounting Box**

3. Connect cables of the main unit and other modules and insert the modules to the mounting box.

---

 **Note**

Apply silicone sealant on the top and sides of the mounting box. Do not apply silicone sealant on the bottom of the box.

---

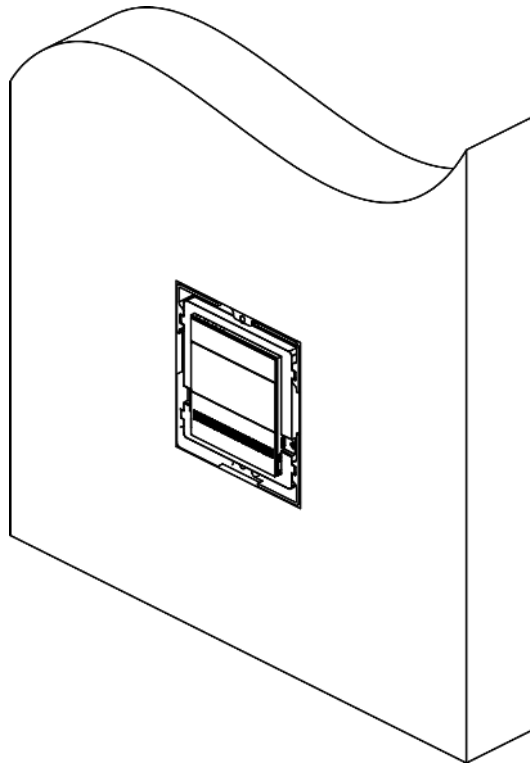

**Figure 3-10 Fix Modules to the Mounting Box**

4. Fix the cover with 2 socket head cap screws by using a hexagon wrench.

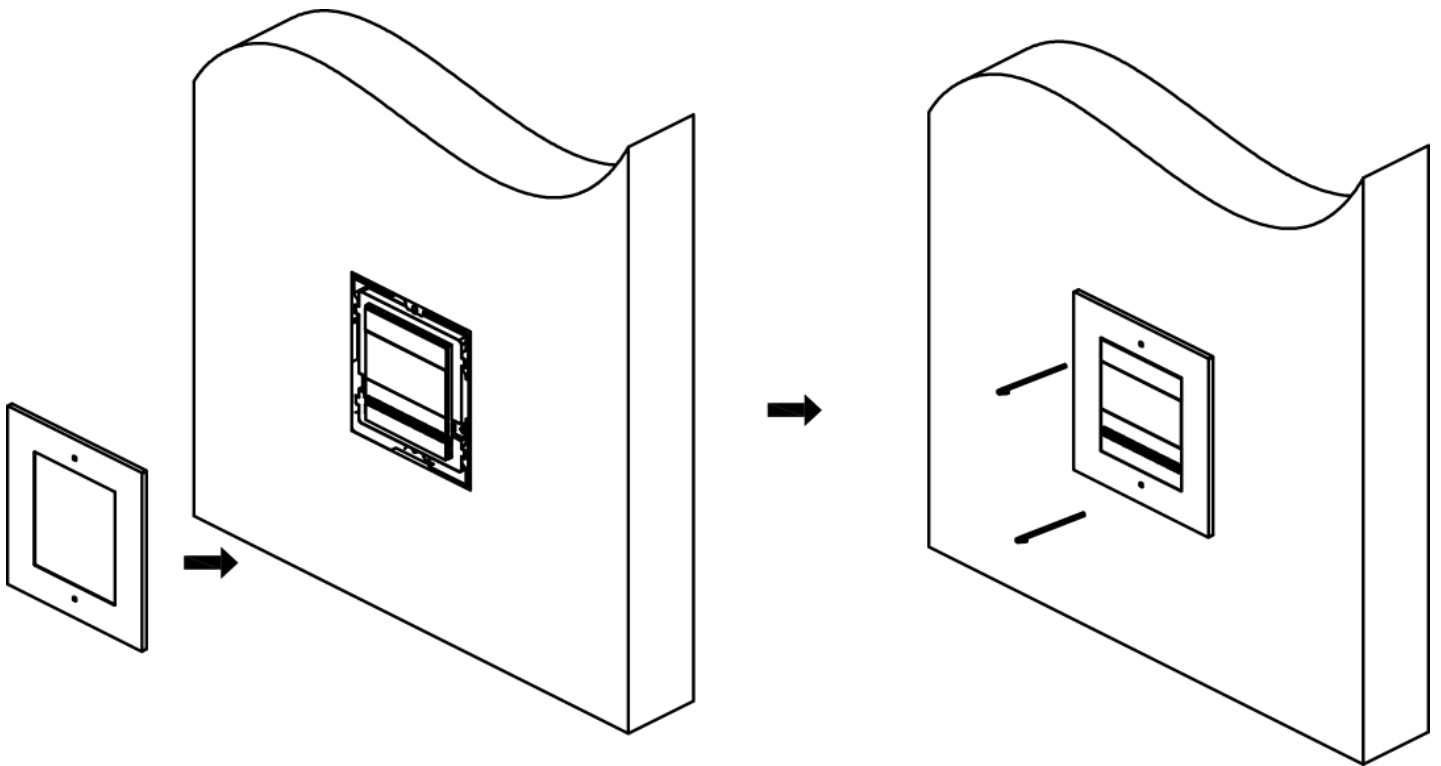

**Figure 3-11 Fix the Cover**

## 3.2 Two-Module Installation

### 3.2.1 Two-Module Surface Mounting

#### Before You Start

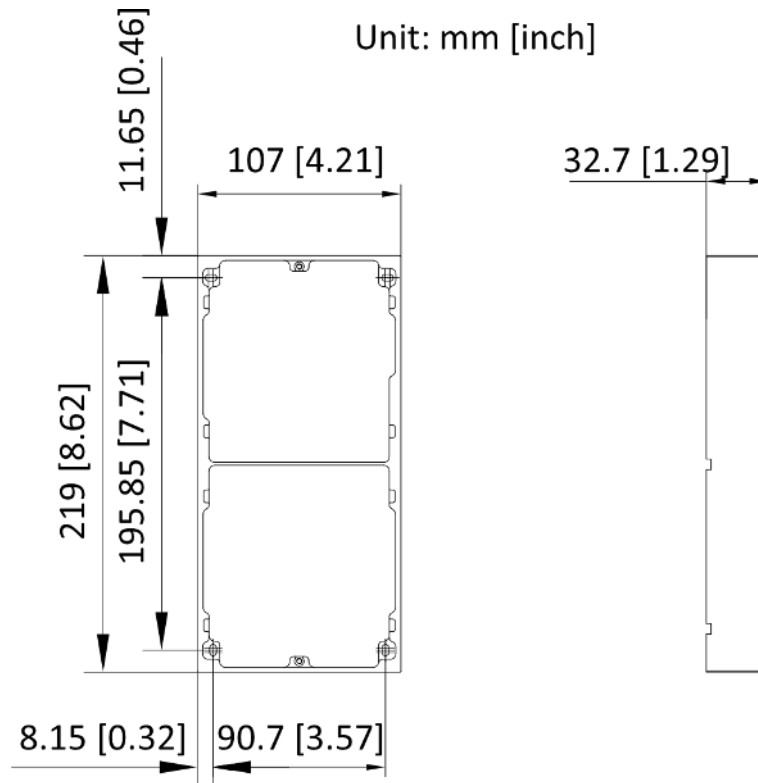

Figure 3-12 Mounting Frame

---

#### Note

- The suggested depth of the installation hole is 33 mm.
- The dimensions above are for reference only. The actual size can be slightly different from the theoretical dimension.

---

#### Steps

1. Stick the mounting sticker to the wall. The suggested length of cables left outside is 270 mm.

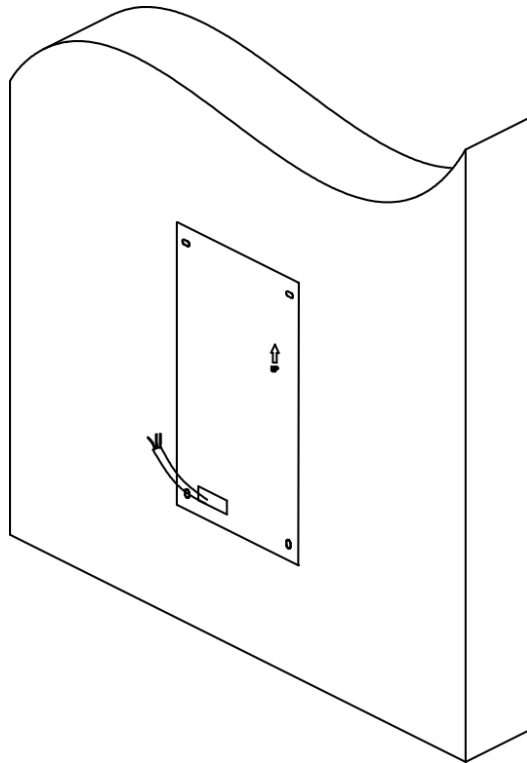

**Figure 3-13 Stick the Sticker**

2. Drill 4 holes of 25 mm deep according to the marks on the sticker and insert the expansion sleeves into the screw holes. Remove the mounting sticker and fix the mounting frame to the wall with 4 expansion bolts.

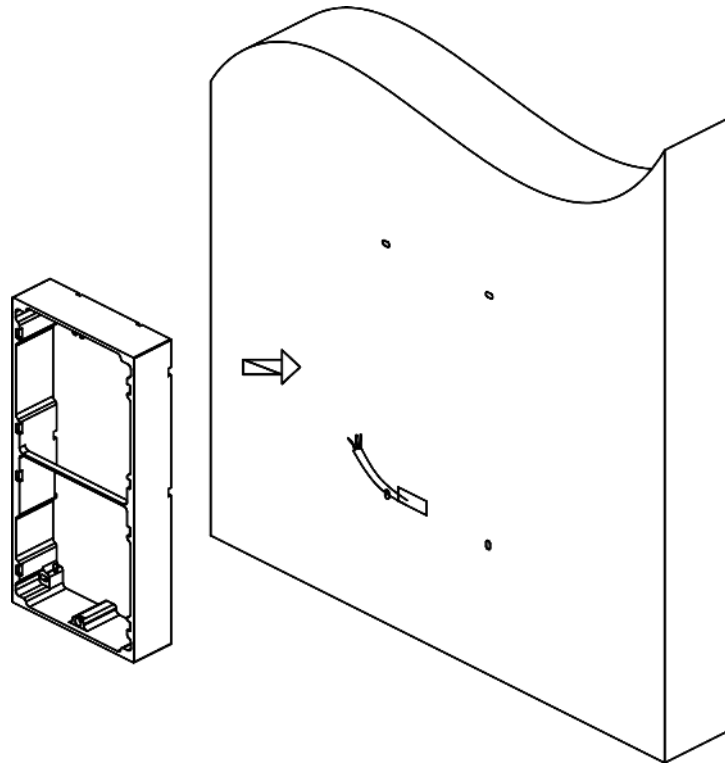

**Figure 3-14 Fix the Mounting Frame**

3. Thread the module-connecting line across the thread holes of the frame. Pass the main unit connecting line across the thread hole to the top grid and connect the cables. Insert the modules into the frame after wiring. The main unit must be placed in the top grid.

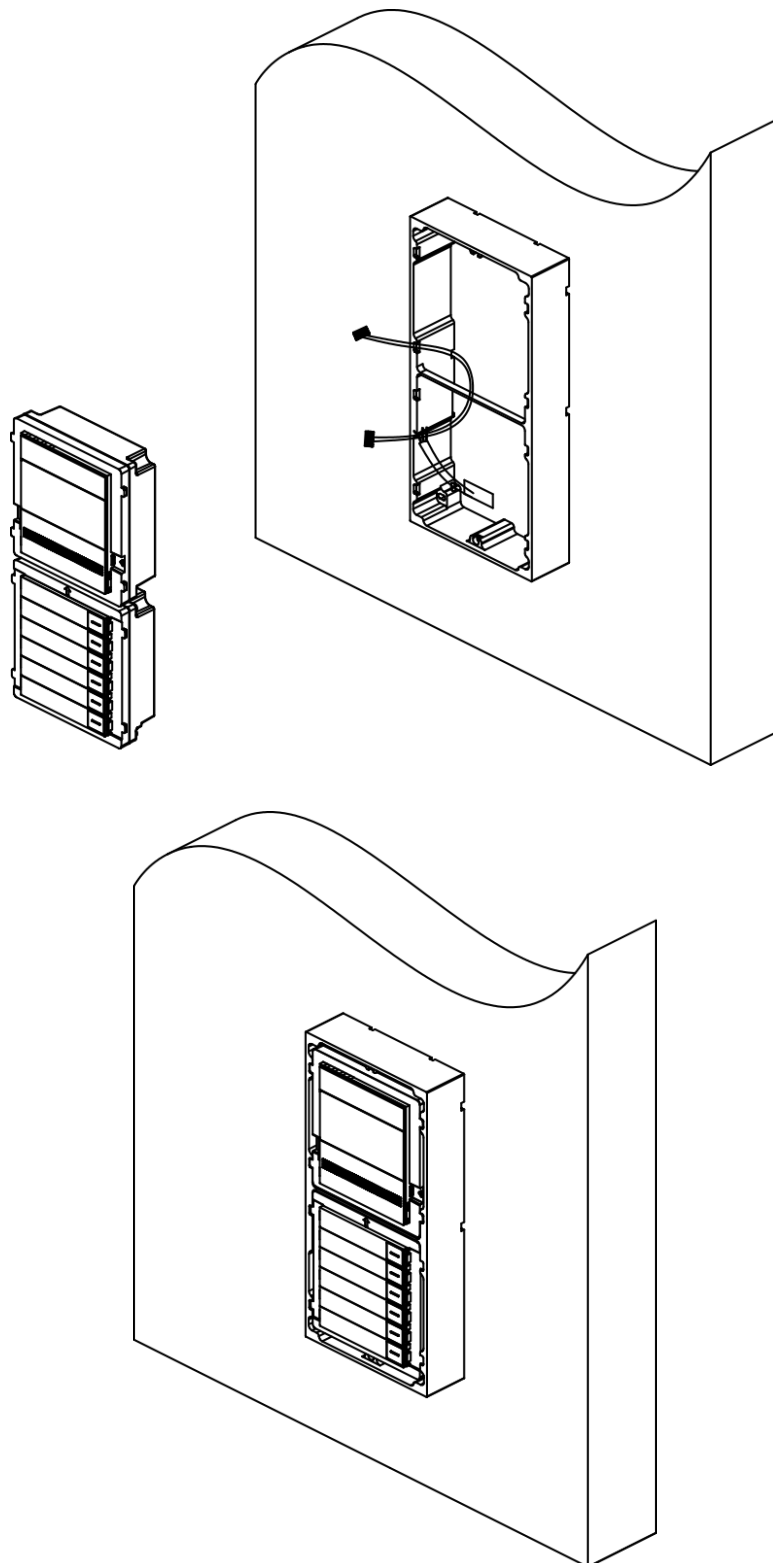

**Figure 3-15 Fix Modules to the Frame**

4. Apply silicone sealant among the cable wiring area to keep the raindrop from entering.

Apply silicone sealant among the cable wiring area to keep the raindrop from entering.

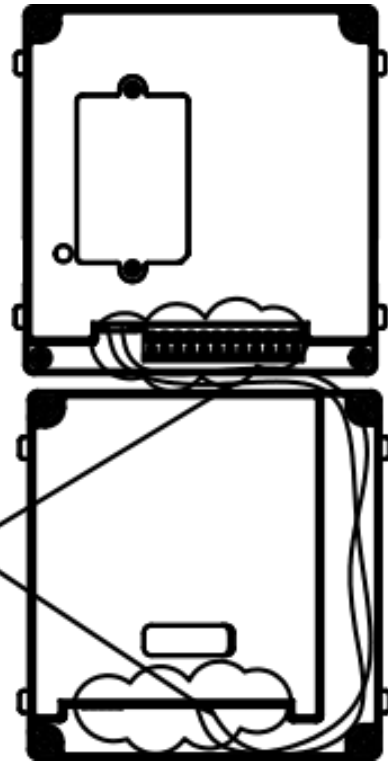

**Figure 3-16 Apply Silicone Sealant**

5. Use the hexagon wrench in the package to fix the cover onto the frame.

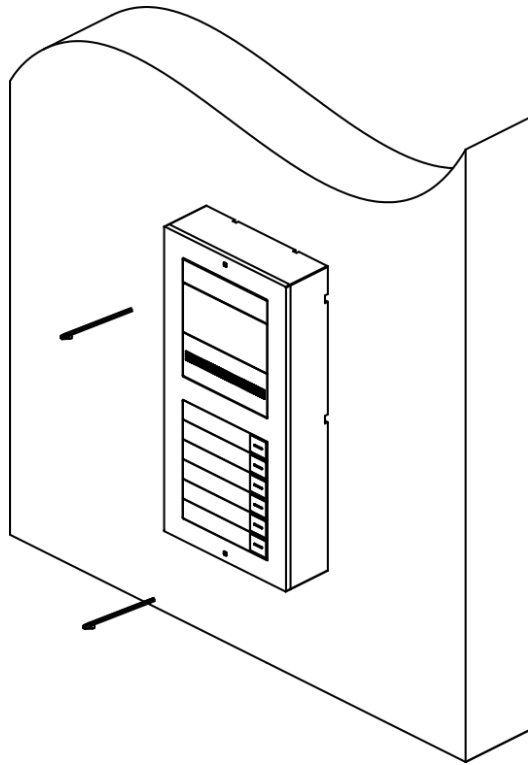

**Figure 3-17 Fix the Cover**

### 3.2.2 Two-Module Flush Mounting

#### Before You Start

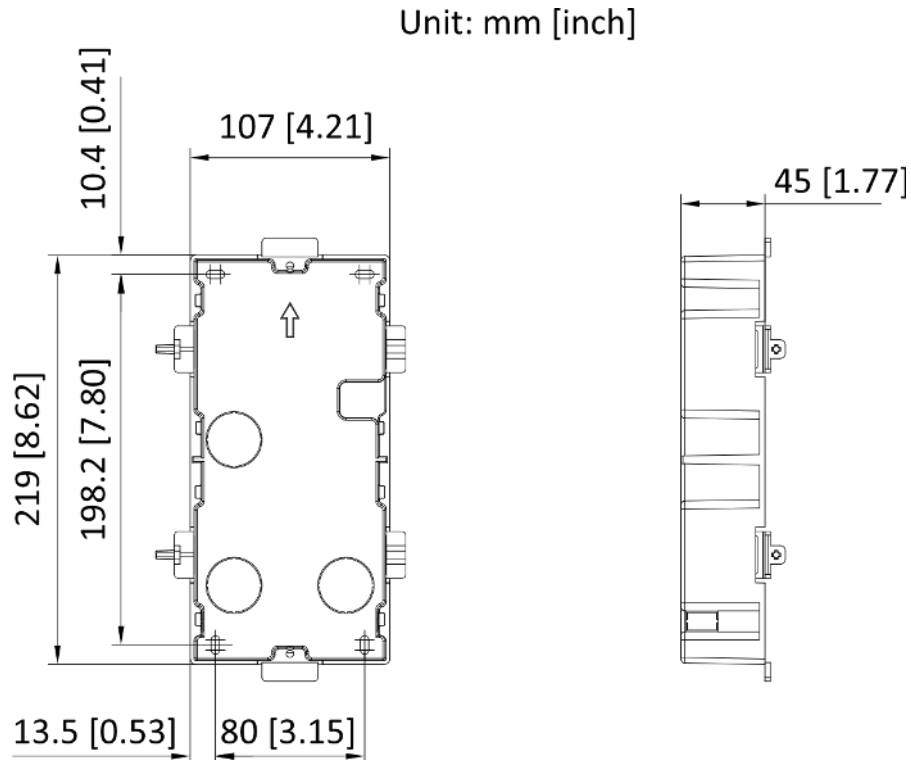

**Figure 3-18 Mounting Box**

---

 **Note**

The dimensions above are for reference only. The actual size can be slightly different from the theoretical dimension.

---

#### Steps

1. Stick the mounting sticker to the wall and cave the installation hole according to the sticker. Pull the cable out. Stick the mounting sticker to the installation hole and drill 4 holes of 25 mm deep according to the marks on the sticker and insert the expansion sleeves into the screw holes.
- 

 **Note**

- The suggested depth of the hole is 44.5 mm.
  - The suggested length of cables left outside is 270 mm.
-

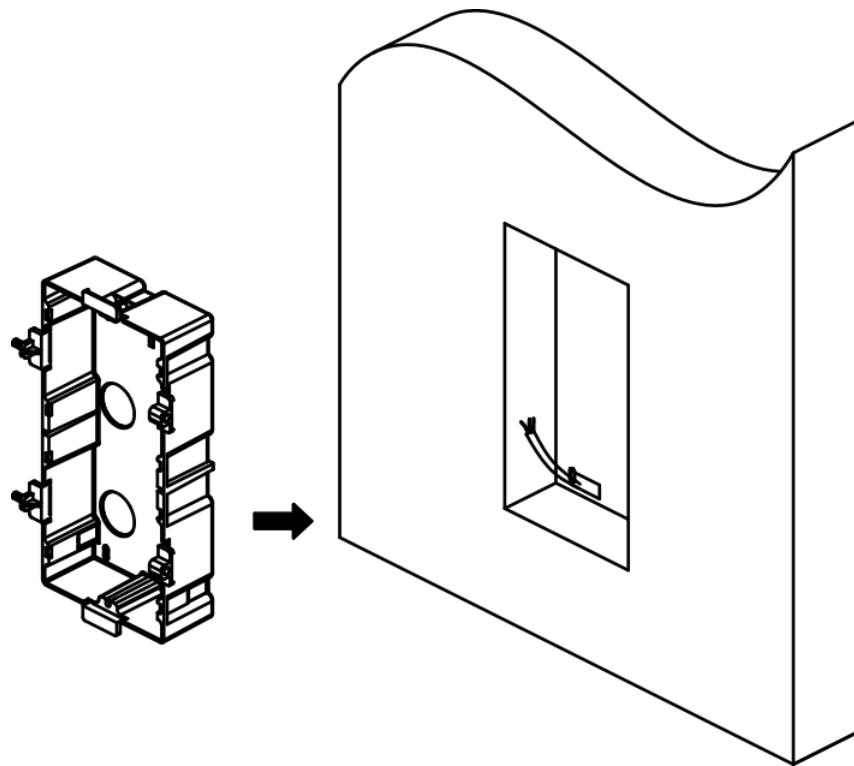

**Figure 3-19 Drill the Installation Hole**

2. Fix the mounting box to the installation with 4 expansion bolts. Remove the positioning piece of the mounting box.

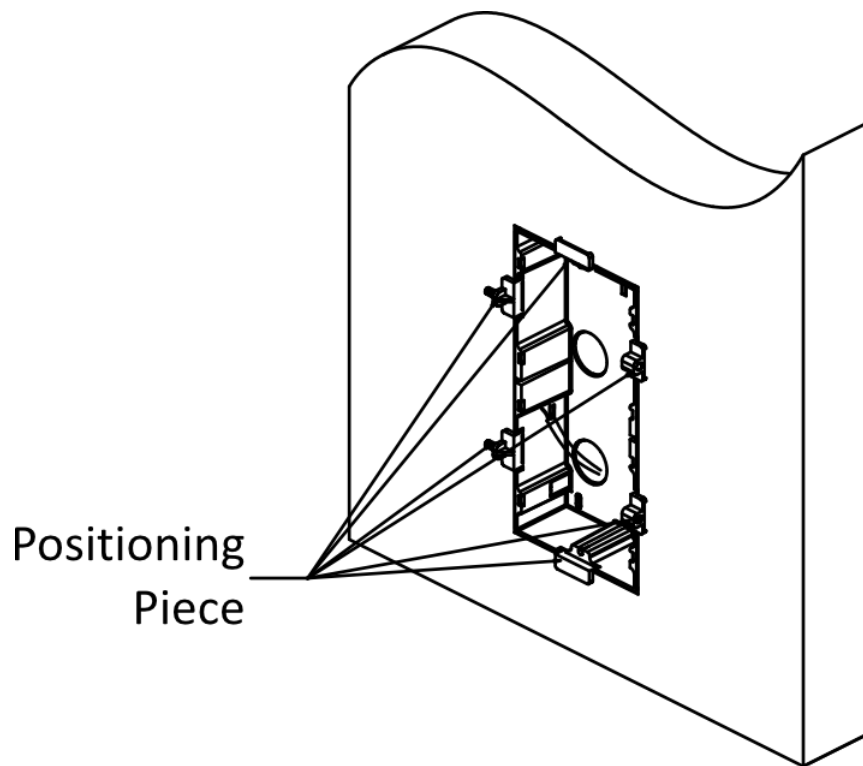

**Figure 3-20 Fix the Mounting Box**

3. Connect cables of the main unit and other modules and insert the modules to the mounting box.

---

 **Note**

Apply silicone sealant on the top and sides of the mounting box. Do not apply silicone sealant on the bottom of the box.

---

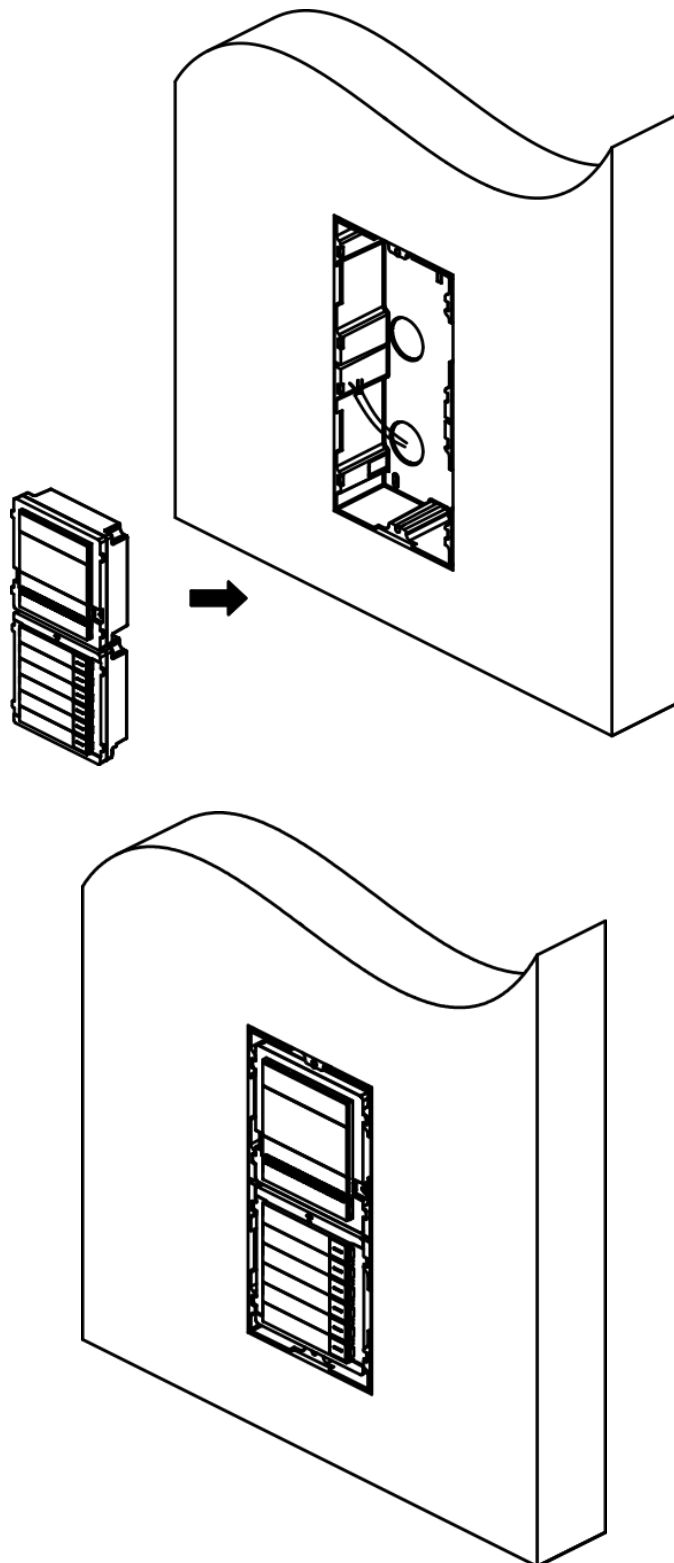
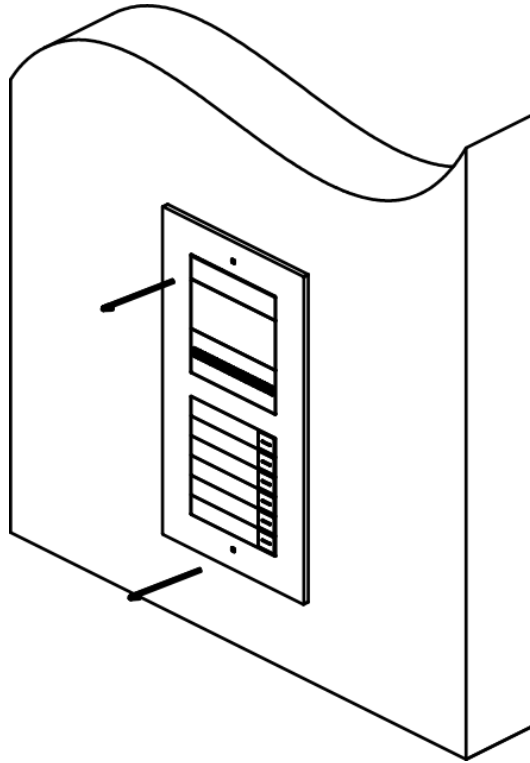

Figure 3-21 Fix Modules to the Mounting Box

4. Fix the cover with 2 socket head cap screws by using a hexagon wrench.



**Figure 3-22 Fix the Cover**

### 3.3 Three-Module Installation

#### 3.3.1 Three-Module Surface Mounting

##### Before You Start

Unit: mm [inch]

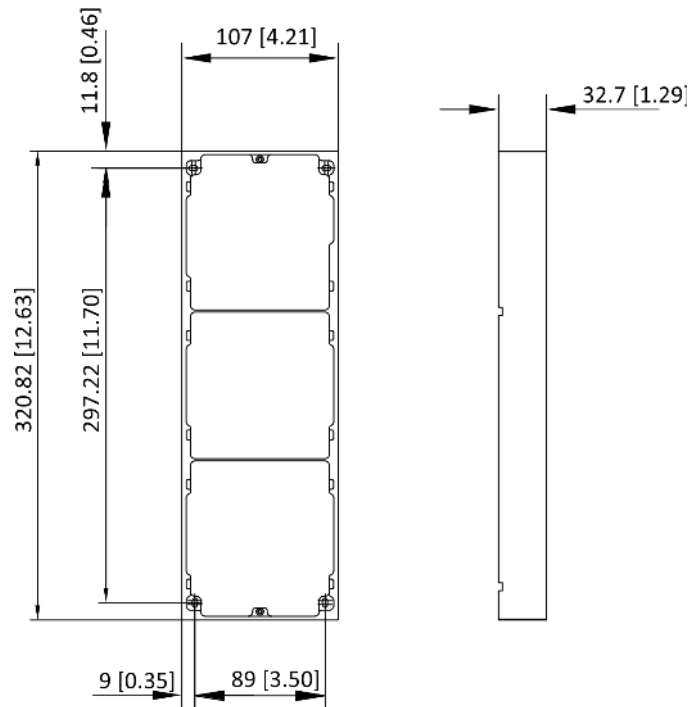

Figure 3-23 Mounting Frame

---

##### Note

- The suggested depth of the installation hole is 33 mm.
- The dimensions above are for reference only. The actual size can be slightly different from the theoretical dimension.

---

##### Steps

1. Stick the mounting sticker to the wall. The suggested length of cables left outside is 270 mm.

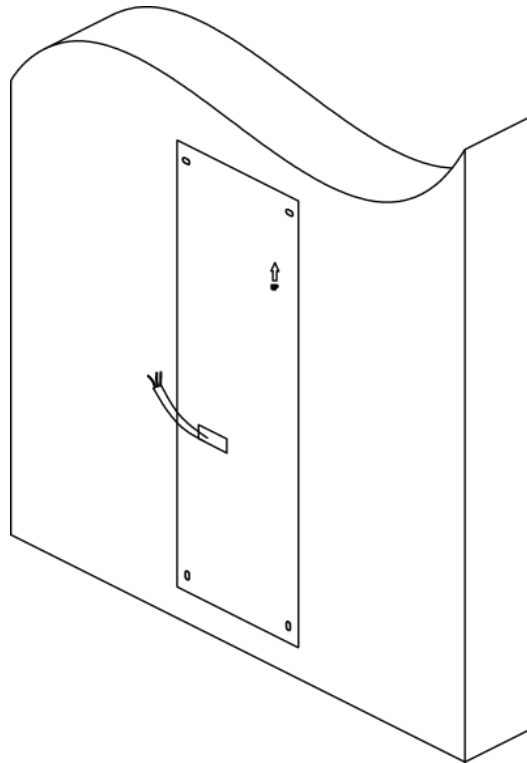

**Figure 3-24 Stick the Sticker**

2. Drill 4 holes of 25 mm deep according to the marks on the sticker and insert the expansion sleeves into the screw holes. Remove the mounting sticker and fix the mounting frame to the wall with 4 expansion bolts.

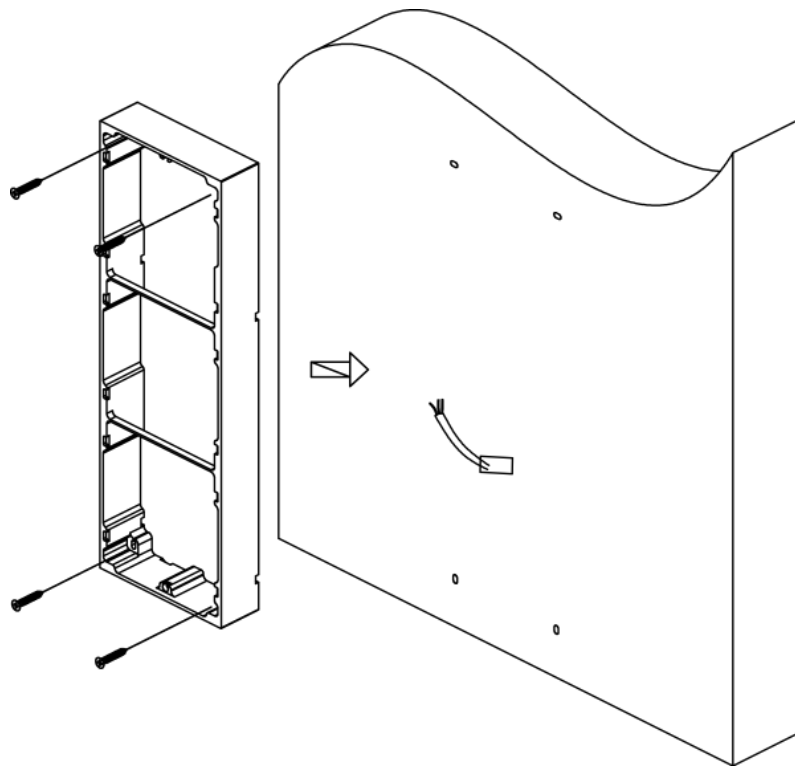

**Figure 3-25 Fix the Mounting Frame**

3. Thread the module-connecting line across the thread holes of the frame.

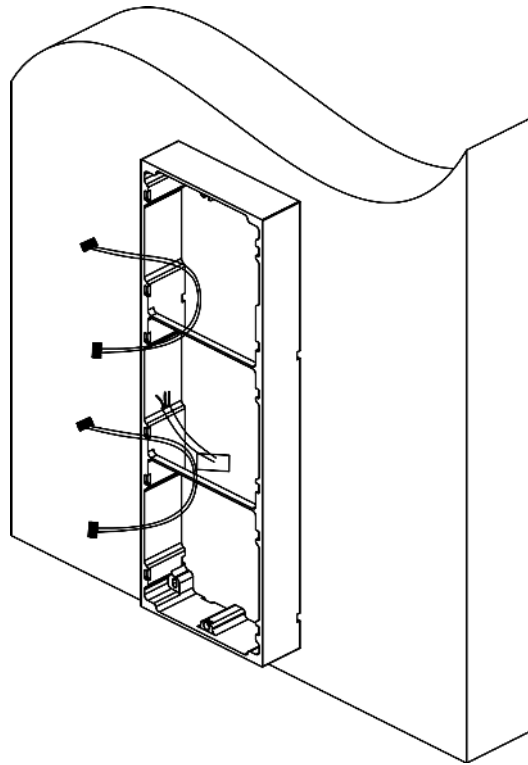

**Figure 3-26 Thread the Module-Connecting Line**

4. Pass the main unit connecting line across the thread hole to the top grid and connect the cables. Insert the modules into the frame after wiring. The main unit must be placed in the top grid.

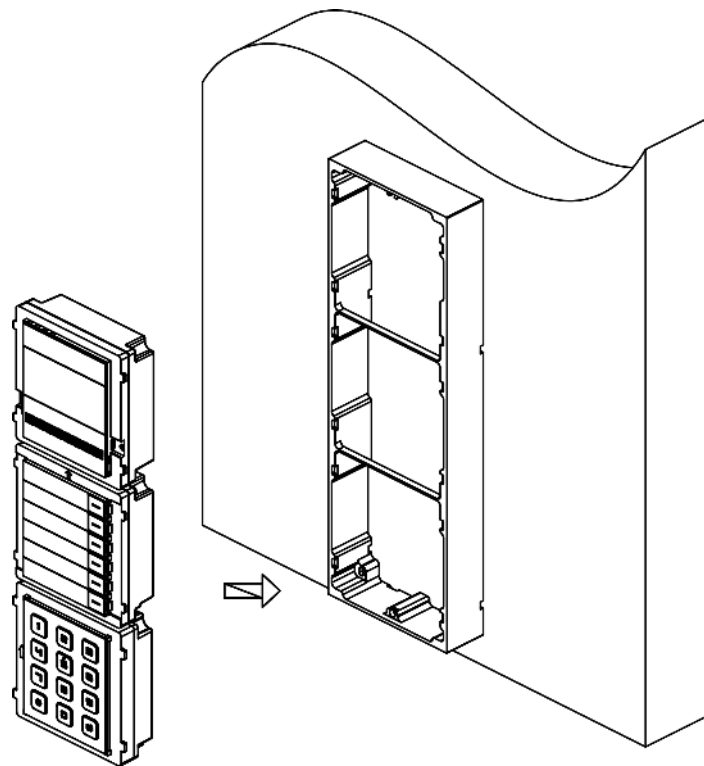

**Figure 3-27 Fix Modules to the Frame**

5. Apply silicone sealant among the cable wiring area to keep the raindrop from entering.

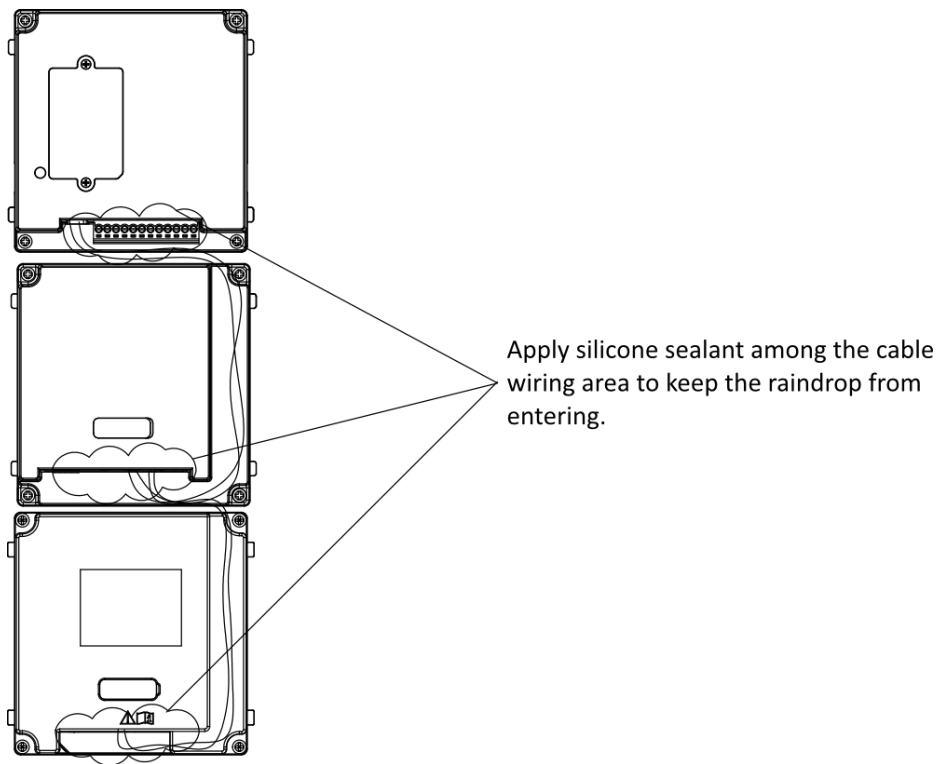

**Figure 3-28 Apply Silicone Sealant**

6. Use the hexagon wrench in the package to fix the cover onto the frame.

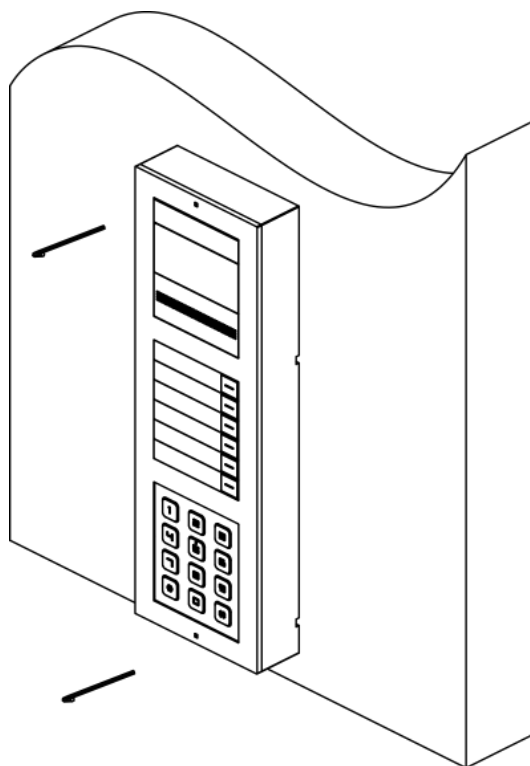

**Figure 3-29 Fix the Cover**

### 3.3.2 Three-Module Flush Mounting

#### Before You Start

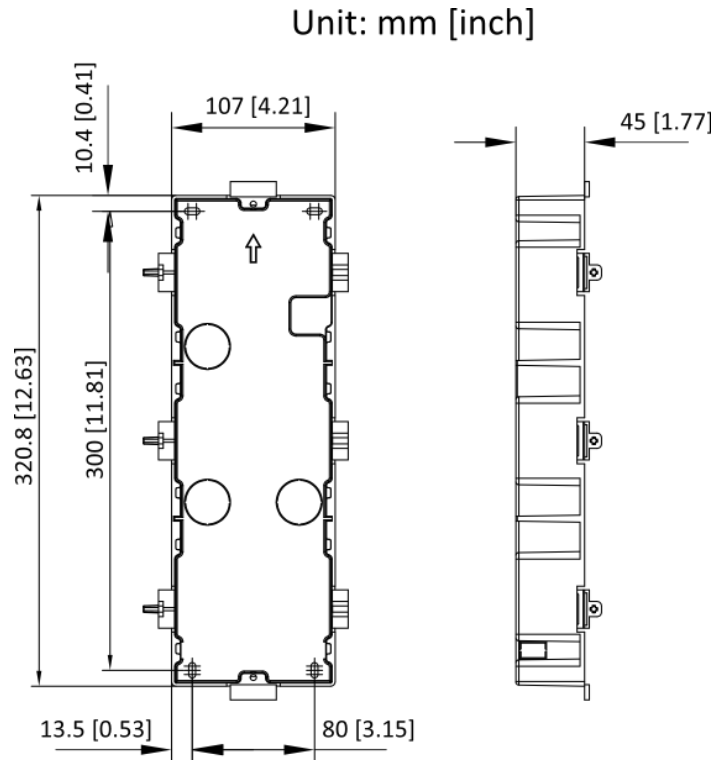

**Figure 3-30 Mounting Box**

---

 **Note**

The dimensions above are for reference only. The actual size can be slightly different from the theoretical dimension.

---

#### Steps

1. Stick the mounting sticker to the wall and cave the installation hole according to the sticker. Pull the cable out. Stick the mounting sticker to the installation hole and drill 4 holes of 25 mm deep according to the marks on the sticker and insert the expansion sleeves into the screw holes.
- 

 **Note**

- The suggested depth of the hole is 44.5 mm.
  - The suggested length of cables left outside is 270 mm.
-

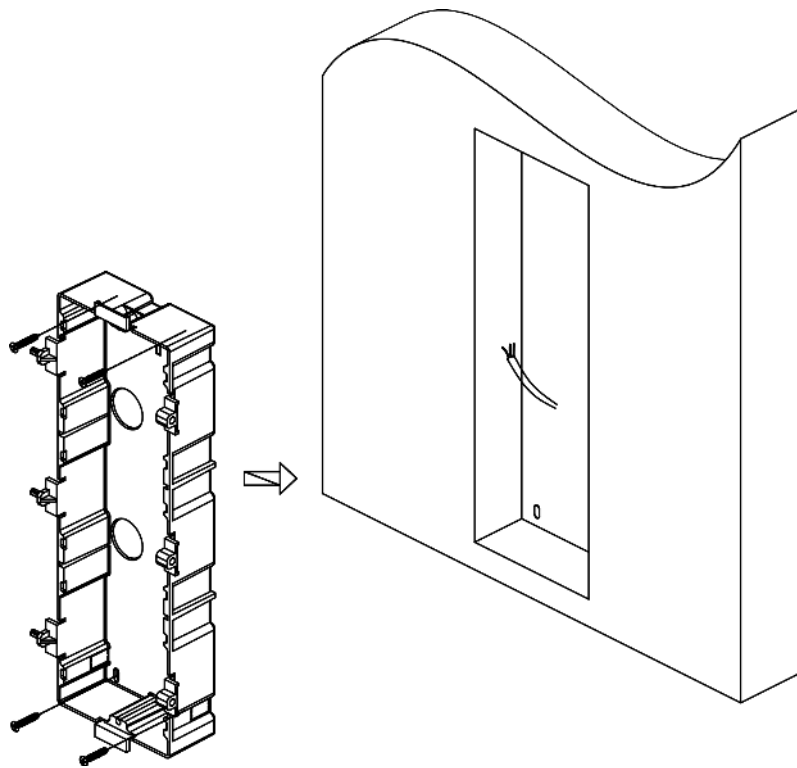

**Figure 3-31 Drill the Installation Hole**

2. Fix the mounting box to the installation with 4 expansion bolts. Remove the positioning piece of the mounting box.

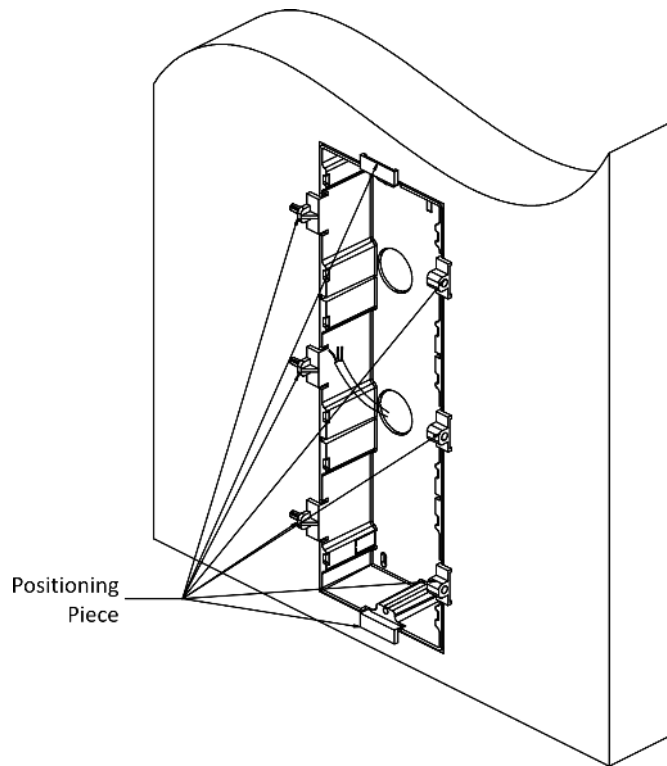

**Figure 3-32 Fix the Mounting Box**

3. Connect cables of the main unit and other modules and insert the modules to the mounting box.

 **Note**

Apply silicone sealant on the top and sides of the mounting box. Do not apply silicone sealant on the bottom of the box.

---

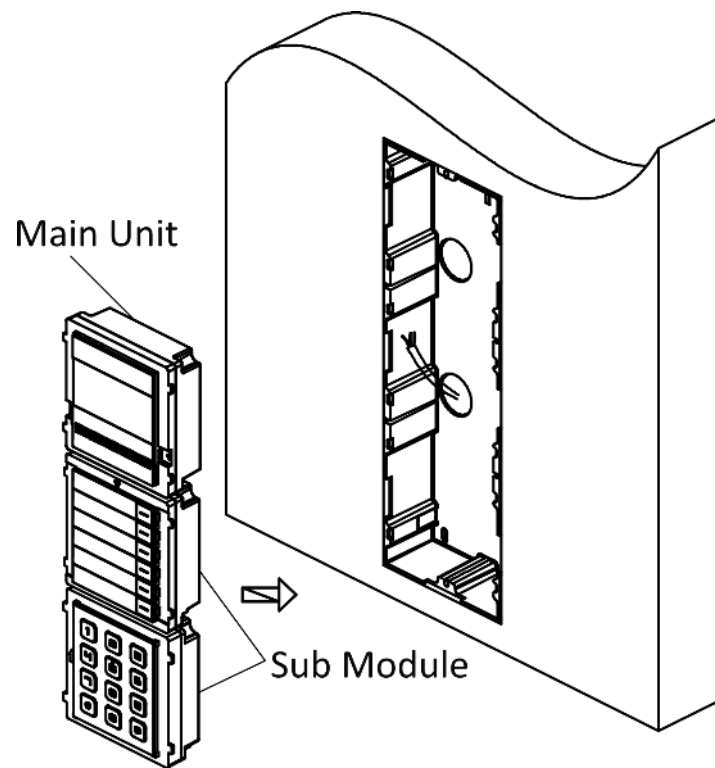

**Figure 3-33 Fix Modules to the Mounting Box**

4. Fix the cover with 2 socket head cap screws by using a hexagon wrench.

Hexagon Wrench

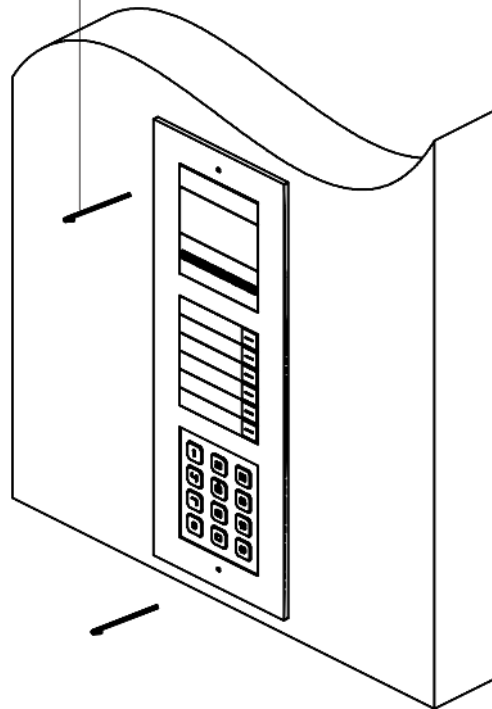

**Figure 3-34 Fix the Cover**

## Chapter 4 Topology

The 2-Wire HD devices can be used in different situations.

- Multi-Family Topology

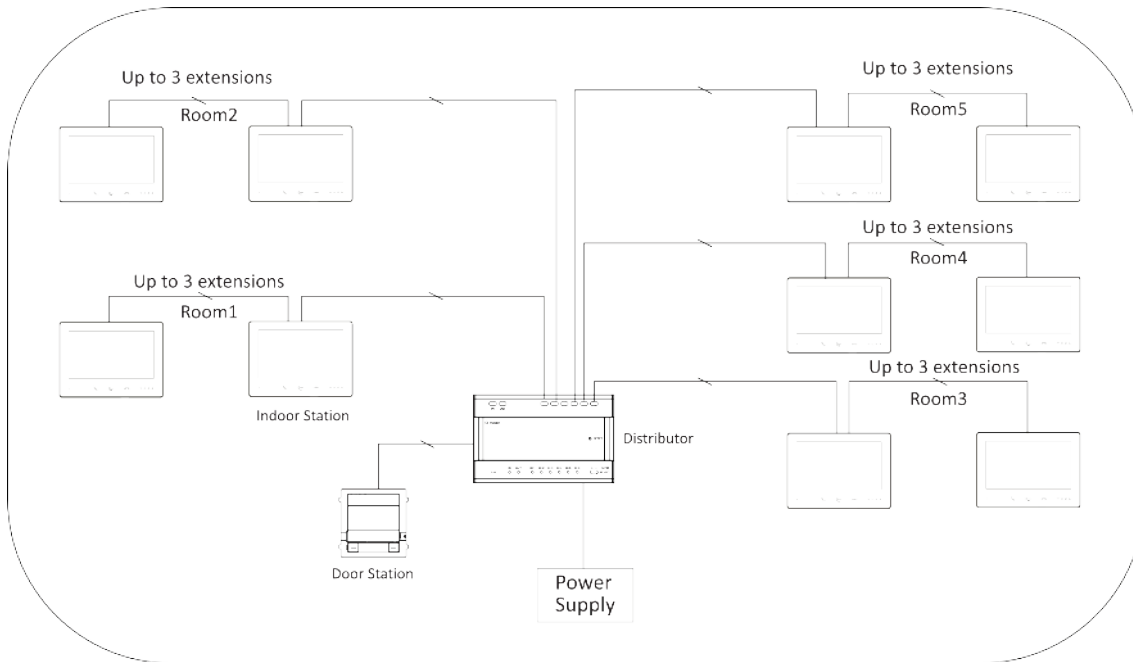

Figure 4-1 Multi-Family Topology



### Note

Each channel of the distributor can be connected to 1 door station / 1 main and 3 sub indoor stations / 8 main indoor stations.

- Single Floor Topology

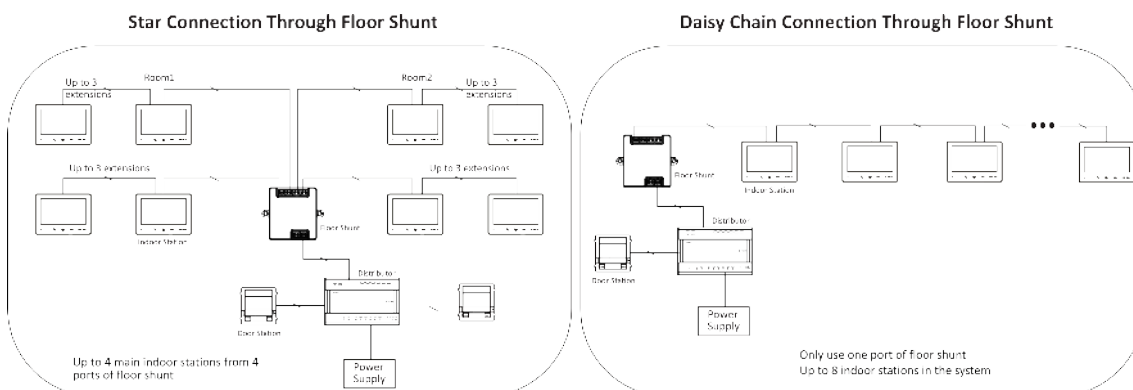
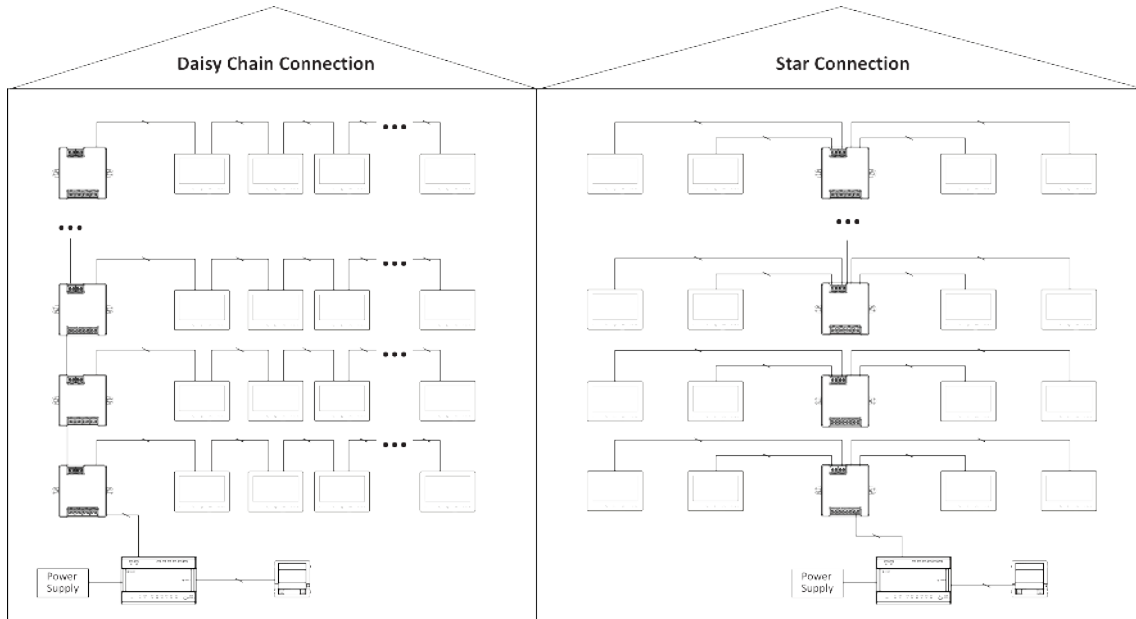

Figure 4-2 Single Floor Topology

- Single Building Topology

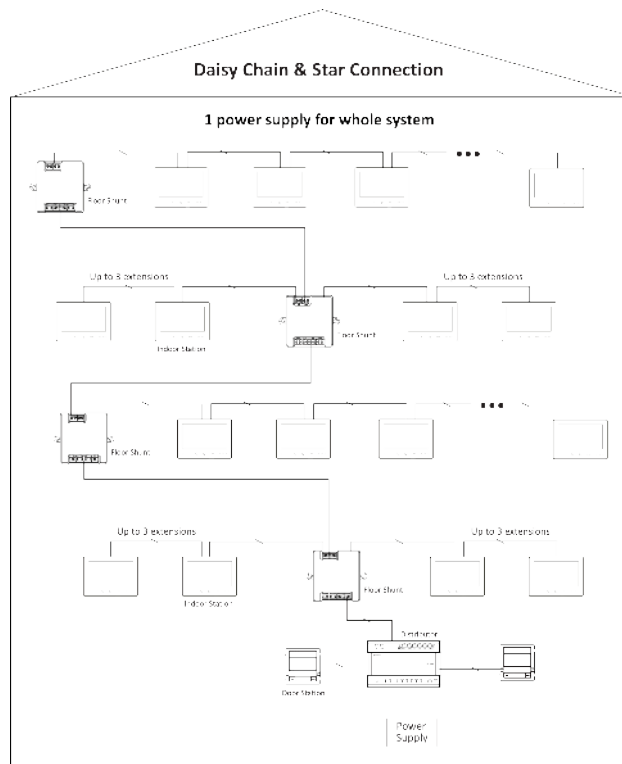

**Figure 4-3 Single Building Topology**

---

**Note**

- Up to 22 indoor stations with Wi-Fi or 64 without Wi-Fi can be used in one building. (The cable needs to be better than AWG20)
  - Up to 16 floor shunts can be cascaded.
- 
- Single Building (Combined)

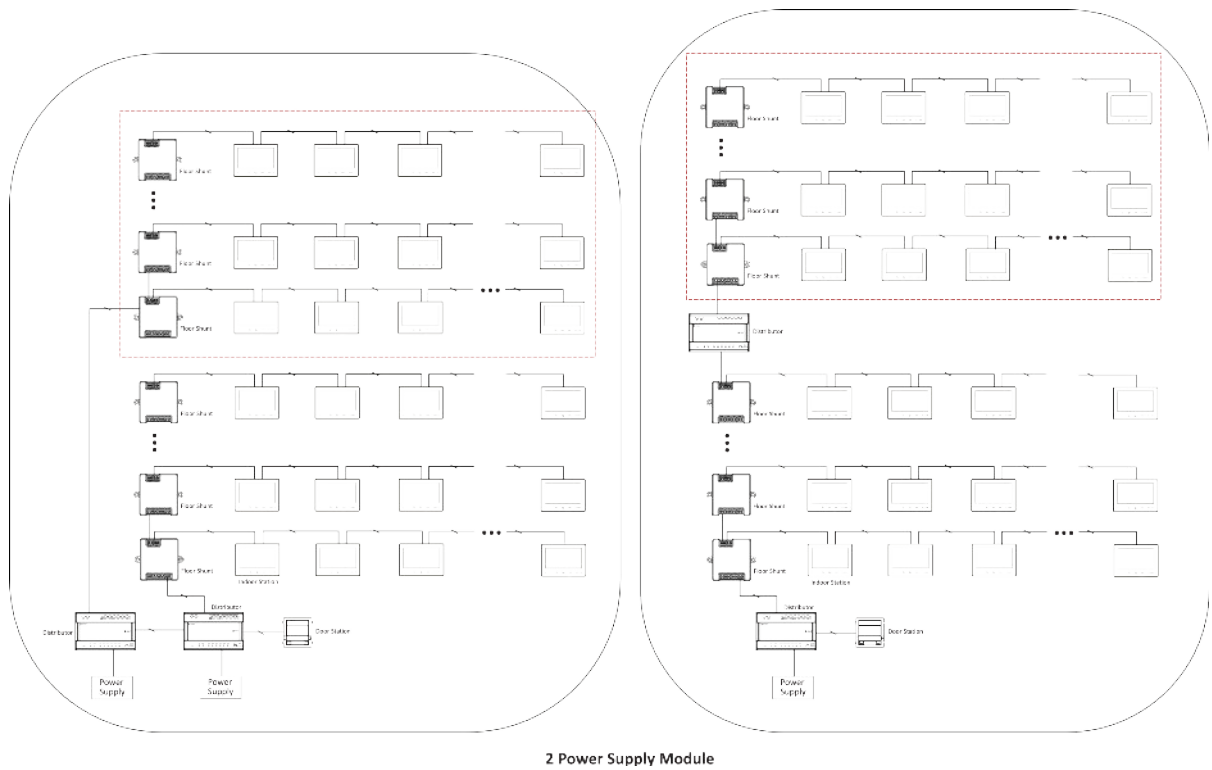

**Figure 4-4 Single Building (Combined)**

**Note**

Due to system power consumption limitations, device needs to be powered separately after 64 or 22 indoor stations are exceeded.

- System Extension in one building

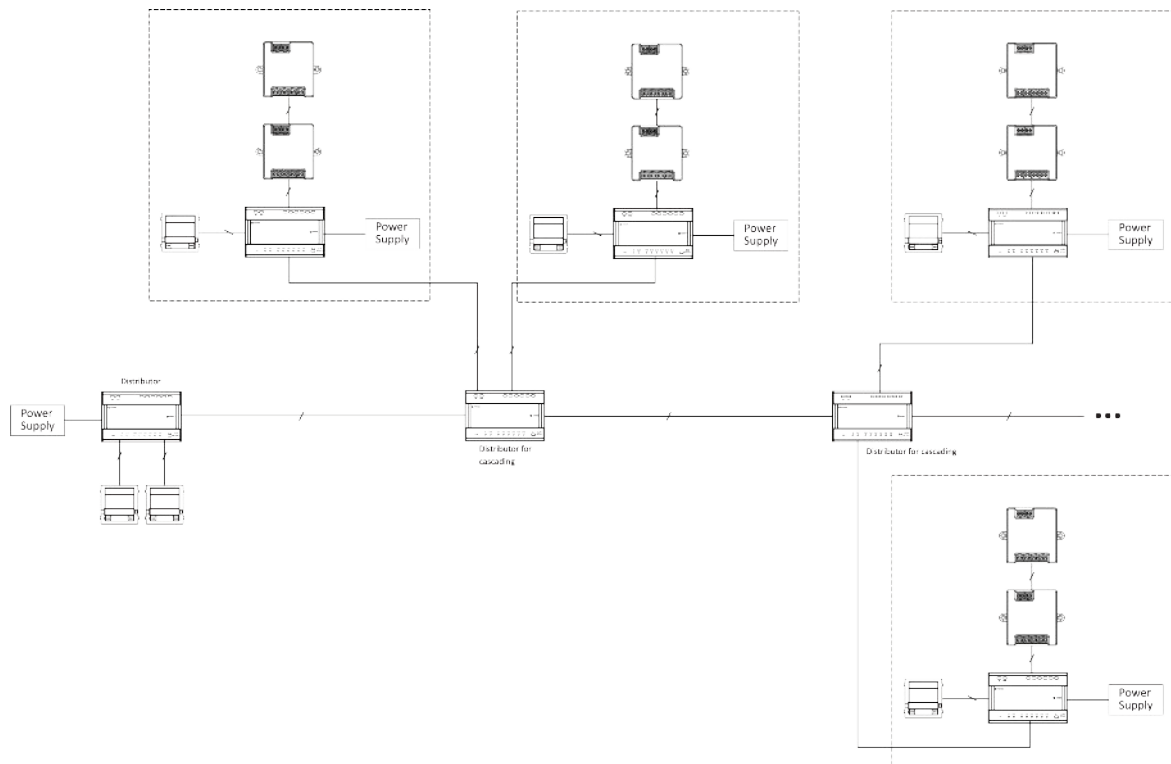

**Figure 4-5 System Extension in one building**

**Note**

Up to 99 indoor stations without Wi-Fi, 44 with Wi-Fi.

- Multiple Building Topology



**Figure 4-6 Multiple Building Topology**

**Note**

- Up to 16 buildings can be connected in the system via the distributor for cascading.
- Up to 10 outer door stations can be connected.
- Up to 16 sub door stations can be connected.

## Chapter 5 Cable and Transmission Distance

Cable and transmission distance between devices should follow rules below.

**Table 5-1 Cable and Transmission Distance**

Cable Type	DS-KAD7061 to DS-KAD7061	DS-KAD7061 to Main Indoor Station	Indoor Station to Indoor Station	DS-KAD7061 to DS-KAD7060	DS-KAD7060 to Power Module/KAD-7060-S	DS-KAD7060 to Door Station	Door Station to Lock (Power Supply)
UTP 5 0.2 mm <sub>2</sub> (Cat. 5) AWG24	60 m	60 m	60 m	60 m	100 m	60 m	NA
0.28 mm <sub>2</sub> (TP) AWG23	60 m	40 m	40 m	40 m	80 m	40 m	30 m
0.5 mm <sub>2</sub> (Parallel) AWG20	60 m	60 m	60 m	60 m	100 m	60 m	50 m
1 mm <sub>2</sub> (Parallel) AWG17	60 m	60 m	60 m	60 m	100 m	60 m	50 m
1 mm <sub>2</sub> (TP) AWG17	60 m	40 m	40 m	40 m	80 m	40 m	100 m
1 mm <sub>2</sub> (Parallel) AWG15	60 m	40 m	60 m	60 m	100 m	60 m	100 m

 **Note**

Distance from power supply to the furthest indoor station is 200 m.

## Chapter 6 Typical Application and Flow

Table 6-1 Typical Application and Flow

Configuration Steps	Details
Device Deployment	Basic Deployment 1. <b><u>Set Device Rotary DIP Switch</u></b> 2. <b><u>Terminal and Wiring</u></b> 3. <b><u>Installation</u></b> 4. Power on the device.
	Advanced Deployment 1. <b><u>Set Device Rotary DIP Switch</u></b> 2. <b><u>Terminal and Wiring</u></b> 3. <b><u>Installation</u></b> 4. Power on the device. 5. Synchronization.
Device Management	1. <b><u>Enable AP Mode</u></b> 2. Log into Mobile Web: <b><u>Login Web Browser</u></b> 3. Device Management: <b><u>Device Management</u></b>
Configuration and Management via Mobile Web	1. <b><u>Enable AP Mode</u></b> 2. Log into Mobile Web: <b><u>Login Web Browser</u></b>
Call	1. Connect Door Station and Indoor Station: <b><u>Topology</u></b> 2. <b><u>Set Device Rotary DIP Switch</u></b> 3. Call: <b><u>Call Indoor Station from Door Station</u></b>
Add or Delete Person via Door Station	1. Log into Mobile or PC Web: <b><u>Login Web Browser</u></b> 2. <b><u>Person Management</u></b>
Unlock via Password	1. Log into Mobile or PC Web: <b><u>Login Web Browser</u></b> 2. - <b><u>Set Public Password on Mobile Web</u></b> - <b><u>Set Public Password on PC Web</u></b> 3. Unlock Door via Public Password

## Chapter 7 Set Device Rotary DIP Switch

After door stations have been connected to indoor stations, you can set rotary DIP switch of these devices.

### DIP Switch of Door Station

Use the rotary switch to set the building No., door station No., sub door station, outer door station No. and door open duration. The Tens column refers to the number in Tens, and the Units column refers to the number in Units. On each rotary DIP switch, 0 to 9 refers to No. 0 to 9. In total, you can use 1 to 99 to number the building. If the door station is main door station, the **Door Station No.** should be set as 0; If it is sub door station, set **Door Station No.** as 1~16; If it is outer door station, set **Door Station No.** as 90~99. Use the screwdriver to adjust the number. The arrow indicates the number.

Building No. (1~99)

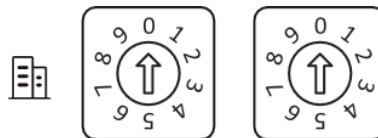

Figure 7-1 Building No.

Door Station No.

Main Door Station: 0

Sub Door Station: 1~16

Outer Door Station : 90~99

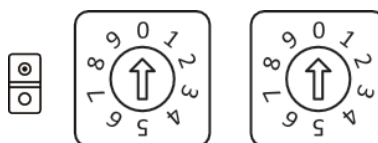

Figure 7-2 DIP Switch of Door Station No.

Door Open Duration

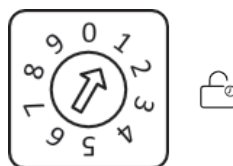

Figure 7-3 DIP Switch of Door Open Duration

Table 7-1 Door Open Duration

Rotary DIP Switch	Door Open Duration(s)
0	2
1	1
2	3
3	4
4	5
5	8
6	10
7/8/9	2

 **Note**

- It is recommended to stick the supplied number remark on the back of the device to indicate the device's No.

**DIP Switch of Indoor Station**

Use the rotary DIP switch to set the indoor extension No., the building No., and the room No. The Tens column refers to the number in Tens, and the Units column refers to the number in Units. On each rotary DIP switch, 0 to 9 refers to No. 0 to 9. In total, you can use 1 to 3 to number the indoor extension No., and use 1 to 99 to number the building or the room. Use the screwdriver to adjust the number. The arrow indicates the number. An example is shown below.

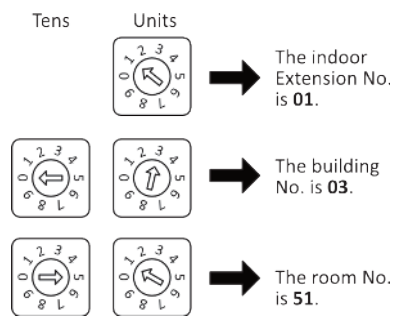
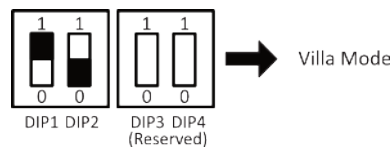
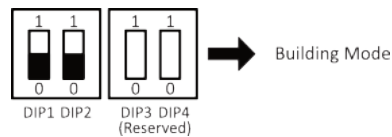

Figure 7-4 Example: DIP Switch of Indoor Station



**Figure 7-5 Villa Mode**

Villa Mode: The device can be powered by separate power supply. Under the villa mode, more than one device can be lightened up; when the extension is called, it can be lightened up and intercom via videos.



**Figure 7-6 Building Mode**

Building Mode: In one power supply system, up to 4 indoor stations can be wired and up to 1 indoor station can be normally used at the same time. When other devices are lightened up, the IN USE indicator will also be lightened up. Separate power supply is not supported. When the extension is called, the screen cannot be lightened up.

---

 **Note**

- DIP 1 and DIP 2 are for mode settings, and DIP 3 and DIP 4 are reserved.
  - If DIP 2 is set as 1, the function of Professional Studio will be enabled.
  - The device is on debugging mode when the extension No. is 9. You can operate the indoor station on debugging mode without connecting to the door station.
-

## Chapter 8 Call Indoor Station from Door Station

After powering on the device, the door station and door station can conduct the following operation.

### **Before You Start**

The indoor station and door station should connect first and finish the settings of DIP switch.

### **Steps**

1. The door station call indoor station directly.
2. The indoor station views the live video of the door station.

## Chapter 9 Unlock Door

### Unlock Door by Public Password

You can unlock the door by public password.

1. Set public password:
  - *Set Public Password on Mobile Web*
  - *Set Public Password on PC Web*
2. Enter **【#】** + Public Password + **【#】** to open the door.

### Unlock Door by Card

1. Add Card: *Person Management*
2. Swipe the card on the card induction area to unlock the door.

## Chapter 10 Enable AP Mode

You can enable AP mode on device or on PC Web.

1. [Enable AP Mode on Device](#)
2. [Enable AP Mode on PC Web](#)

### 10.1 Enable AP Mode on Device

You can enable the AP mode on device. After enabling the AP mode, you can log into the Web Client of the door station for configuration with your mobile devices via the hotspot.

#### Steps

1. Long press the button on the left side of the device to enable the AP mode.



#### Note

The AP mode will last for 30 minutes by default. 30 minutes after the AP mode is enabled, it will disable automatically.

---

### 10.2 Enable AP Mode on PC Web

You can enable the AP mode via enabling the **Device Hotspot** function on PC Web. After enabling the AP mode, you can log into the Web Client of the door station for configuration with your mobile devices via the hotspot.

Log into the Web Client, click **Configuration** → **Network** → **Network Settings** → **Device Hotspot** . Click **Save** to save the settings.

### 10.3 FAQ of AP Mode

The FAQ of AP Mode is listed as follows.

1. Q: How to enable AP mode of door station?  
A: Long press the left button for 10 s and you will hear sound **beep** and the back light will flashing for 2 minutes to indicate.

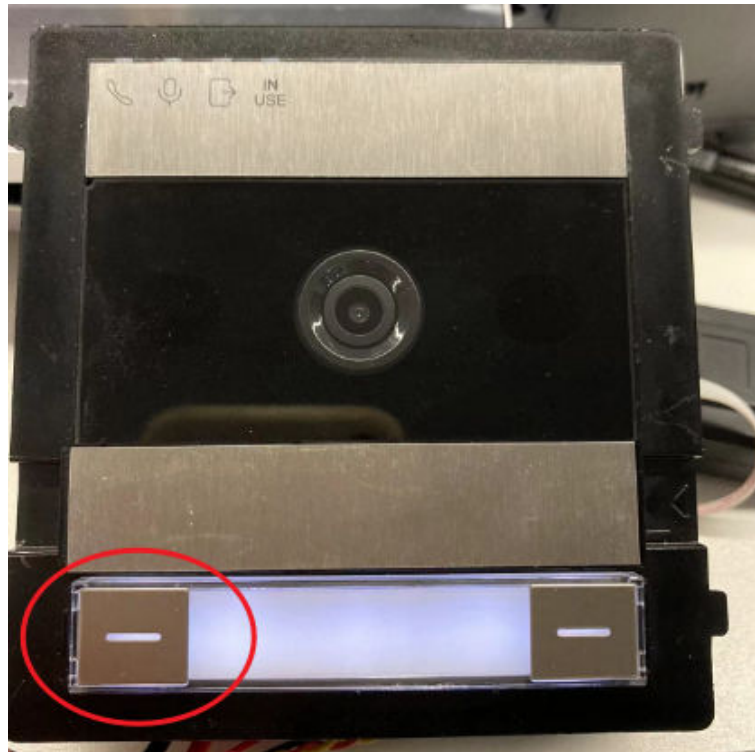

**Figure 10-1 Long press the left button**

---

 **Note**

if your device doesn't have left button, please remove the cover then you can see the button.

---

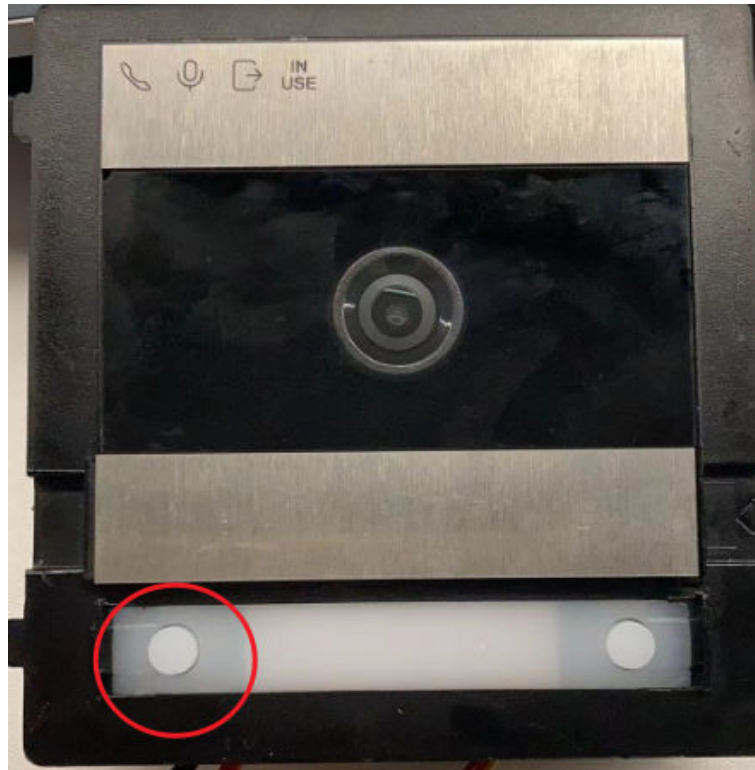

**Figure 10-2 Remove the cover**

2. Q: What is the default password of device hotspot?

A: The hotspot SSID name is **AP\_device SN**, for example, **AP\_K12345678**. Before activation, the Wi-Fi password is on the label of door station. After activation and after login in mobile phone browser, you can modify the device activation and Wi-Fi password.

3. Q: I enabled the AP mode some time ago, but now I can't search the hotspot with my mobile phone or laptop.

A: The AP mode will be disabled automatically after 30 minutes, if you cannot search the Wi-Fi, please enable it manually again by long pressing left button for 10 s.

---

 **Note**

When the AP mode is enabled, if long pressing the left button for 10 s, the AP mode will start a new 30-minute countdown.

---

4. Q: How to disable the AP mode?

A: Just long press the left button for 15 s. Or if no device connects the AP, it will be disabled in 30 minutes automatically.

## Chapter 11 Login Web Browser

You can log into the Web browser for device configuration.

### Steps

1. Connect your mobile devices or PCs to the device hotspot.
2. Enter the device user name and the activation password. Click **Login**.



### Note

The device will be activated automatically after powered on. You can check the activation password via the label on the surface of the device.

3. For the first-time login, you need to change the activation password: Click **admin** → **Modify Password** on the upper right of the Web browser page. Enter the old and new password and confirm the new password. Click **Save**.



### Note

- The new password will take effect after rebooting.
  - The hotspot password will be changed simultaneously after the activation password is changed.
-

## Chapter 12 Forgot Password

If you forget the password when logging in, you can change the password via PC Web or mobile Web.

1. [Forgot Password via PC Web](#) .

2. [Forgot Password via Mobile Web](#)

### 12.1 Forget Password via Mobile Web

If you forget the password when logging in, you can change the password by email address or security questions.

On the login page, tap **Forget Password**.

Select **Verification Mode**.

#### Security Question Verification

Answer the security questions.

#### E-mail Verification

1. Export the QR code and send it to [pw\\_recovery@hikvision.com](mailto:pw_recovery@hikvision.com) as attachment.
2. You will receive a verification code within 5 minutes in your reserved email.
3. Enter the verification code into the verification code field to verify your identification.

Click **Next**, create a new password and confirm it.

### 12.2 Forget Password via PC Web

If you forget the password when logging in, you can change the password by email address or security questions.

On the login page, click **Forget Password**.

Select **Verification Mode**.

#### Security Question Verification

Answer the security questions.

#### E-mail Verification

1. Scan the QR code via mobile device.
2. You will receive a verification code within 5 minutes in your reserved email.
3. Enter the verification code into the verification code field to verify your identification.

Click **Next**, create a new password and confirm it.

## Chapter 13 Overview

You can take an overview of the PC Web and mobile Web page.

1. [Overview on PC Web](#)
2. [Overview on Mobile Web](#)

### 13.1 Overview on Mobile Web

You can view the door status, network status and basic information, and set person management, smart settings, authentication settings, and door parameters via shortcut entry.

Function Descriptions:

#### Door Status



To set the door status as unlock/remaining open or to restore the settings.

#### Device Component Status

You can view the device component status.

#### Building Information

You can view the Building No., Door Station No. and Duration of Remaining Open.

#### Shortcut Entry

You can quickly access to the following settings page via **Shortcut Entry**.

- [Device Management](#)
- [Person Management](#)
- [Forgot Password](#)
- [Set Door Parameters on Mobile Web](#)

#### Basic Information

You can view the model, serial No. and firmware version.

### 13.2 Overview on PC Web

You can view the live video of the device, real-time event, person information, network status, basic information, and device capacity.

Function Descriptions:

#### Door Status



You can capture image when starting live view.



Select the streaming type when starting live view. You can select from the main stream and the sub stream.



Full screen view.



To set the door status as unlock/remaining open or to restore the settings.

### **Controlled Status**

You can select **Unlock/ Restore/ Remain Open** according to your actual needs.

### **Device Component Status**

You can view the device component status.

### **Building Information**

You can view the Building No., Door Station No. and Duration of Remaining Open.

### **Linked Device**

You can view information of linked sub door station, indoor station and indoor extension.

### **Person Information**

You can view the added and not added information of person.

### **Basic Information**

You can view the model, serial No. and firmware version information.

### **Device Capacity**

You can view the person and card capacity.

## Chapter 14 Person Management

You can manage person information on PC Web and mobile Web.

- [Person Management on PC Web](#)
- [Person Management on Mobile Web](#)

### 14.1 Person Management on Mobile Web

You can add, edit, delete, and search users via mobile Web browser.

#### Steps

1. Tap  → **Person Management** to enter the settings page.
2. Add user.
  - 1) Tap+.
  - 2) Set the following parameters.

#### Employee ID

Enter the employee ID. The Employee ID cannot be 0 or exceed 32 characters. It can be a combination of uppercase, lowercase letters and numbers.

#### Name

Enter your name. The name supports numbers, uppercase and lowercase English, and characters. The name is recommended to be within 32 characters.

#### Room No.

Enter the Room No.



#### Note

The room No. refers to the mapping room No. which you can custom the No. on your own.

---

#### Long-Term Effective User

Set the user permission as long-term effective.

#### Start Date/End Date

Set **Start Date** and **End Date** of user permission.

#### Administrator

If the user needs to be set as administrator, you can enable **Administrator**.

#### User Role

Select your user role.

#### Card

Add card. Tap **Add Card**. Enter the **Card No.**, or present the card on the device and tap **Read**, and select the **Property**. Tap **Save** to add the card.

### Fingerprint

Add fingerprint. Tap **Fingerprint**, then tap **+**, and add fingerprint via the fingerprint module.

3) Tap **Save**.

3. Tap the user that needs to be edited in the user list to edit the information.

4. Tap the user that needs to be deleted in the user list, and tap  to delete the user.

5. You can search the user by entering the employee ID or name in the search bar.

## 14.2 Person Management on PC Web

Click **Add** to add the person's information, including the basic information, certificate, authentication and settings.

### Add Basic Information

Click **Person Management** → **Add** to enter the Add Person page.

Add the person's basic information, including the employee ID, the person's name, person type, etc.

Click **Save** to save the settings.

### Set Permission Time

Click **Person Management** → **Add** to enter the Add Person page.

Enable **Long-Term Effective User**, or set **Start Time** and **End Time** and the person can only has the permission within the configured time period according to your actual needs.

Click **Save** to save the settings.

### Add Administrator

Click **Person Management** → **Add** to enter the Add Person page.

Tap to enable **Administrator**, and the person you add will be administrator.

Click **Save** to save the settings.

### Add Card

Click **Person Management** → **Add** to enter the Add Person page.

Click **Add Card**, enter the **Card No.** and select the **Property**, and click **OK** to add the card.

Click **Save** to save the settings.

### Add Fingerprint

Click **Person Management** → **Add** to enter the Add Person page.

Click **Add Fingerprint**, and press your finger on the fingerprint module of the device to add your fingerprint.

Click **Save** to save the settings.

### Set Room No.

Click **Person Management** → **Add** to enter the Add Person page.

Click **Add**, enter the **Room No.** to add the room.

---

### **Note**

The room No. refers to the mapping room No. which you can custom the No. on your own.

---

Click **Save** to save the settings.

### **Set Door Permission**

Click **Person Management** → **Add** to enter the Add Person page.

Select Door 1 or Door 2, to configure the door permission of the person.

Click **Save** to save the settings.

### **View/edit Person**

Click **Person Management** → **Add** to enter the Add Person page.

You can filter a person by entering the employee ID, name or card No.

You can view added people under the mode of card or list. You can click the card of the person or the editing icon to edit the information of the person.

Click **Save** to save the settings.

## Chapter 15 Device Management

You can manage the linked device on PC Web and mobile Web.

- [\*\*View Room No. Details on Mobile Web\*\*](#)
- [\*\*Device Management on PC Web\*\*](#)

### 15.1 View Room No. Details on Mobile Web

You can view the room No. details of linked indoor station.

#### Steps

1. Tap **Device Management** on the main page of mobile Web.
2. Tap the room to view the room details.

### 15.2 Device Management on PC Web

#### Synchronization from Door Station/Outer Door Station

Long press to button on the right side of the device to synchronize information.

#### Add Device

Click **Device Management** to enter the settings page. Select device type and configure room information to add device.

#### Upgrade / Delete Device

You can upgrade, edit and delete device.



#### Note

All indoor stations should be online before upgrading.

---

## Chapter 16 View Device Information

You can view device information on PC Web and mobile Web.

- [\*\*View Device Information on Mobile Web\*\*](#)
- [\*\*View Device Information on PC Web\*\*](#)

### 16.1 View Device Information on Mobile Web

View the device name, No., language, model, serial No., QR code, version, Number of channels, IO Input, IO Output, Local RS-485, Alarm Input/Output, MAC Address and Device Capacity, etc.

Tap **Configuration** → **System** → **System Settings** → **Basic Information** to enter the configuration page.

You can view the device name, No., language, model, serial No., QR code, version, Number of channels, IO Input, IO Output, Local RS-485, Alarm Input/Output, MAC Address and Device Capacity, etc.

### 16.2 View Device Information on PC Web

View the device name, device No., language, model, serial No., version, number of channels, IO input, IO output, lock, alarm input, alarm output, and device capacity, etc.

Click **Configuration** → **System** → **System Settings** → **Basic Information** to enter the configuration page.

You can view the device name, device No., language, model, serial No., version, number of channels, IO input, IO output, lock, alarm input, alarm output, and device capacity, etc.

## Chapter 17 Time Settings

You can set time/DST on PC Web and mobile Web.

- [Set Time on Mobile Web](#)
- [Set DST on Mobile Web](#)
- [Set Time on PC Web](#)
- [Set DST on PC Web](#)

### 17.1 Set Time on Mobile Web

Set the time zone, time sync. mode, and displayed time.

Tap  → **System Settings** → **Time Settings** to enter the settings page.

Tap **Save** to save the settings.

#### Time Zone

Select the time zone where the device is located from the drop-down list.

#### Time Sync. Mode

##### Manual

By default, the device time should be synchronized manually. You can set the device time manually.

### 17.2 Set DST on Mobile Web

#### Steps

1. Tap  → **System Settings** → **Time Settings** , to enter the settings page.

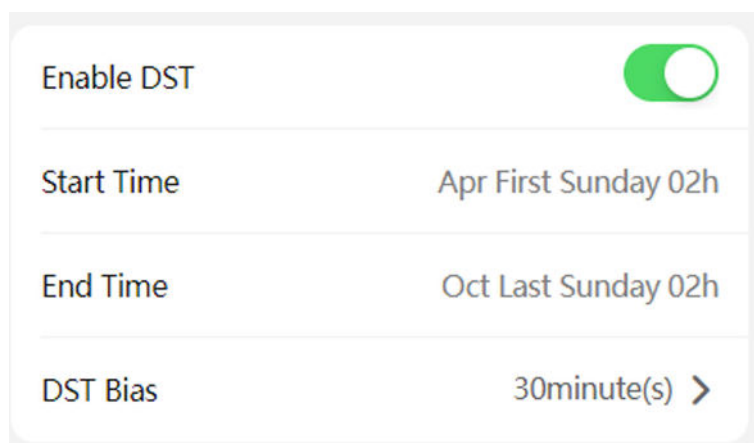

Figure 17-1 DST

2. Tap **Enable DST**.
3. Set the start time, end time, and DST bias.
4. Tap **Save**.

## 17.3 Set Time on PC Web

Set the device's time zone, synchronization mode, server address, NTP port, and interval.

Click **Configuration** → **System** → **System Settings** → **Time Settings** .

Click **Save** to save the settings after the configuration.

### Time Zone

Select the device located time zone from the drop-down list.

### Time Sync.

#### Manual

By default, the device time should be synchronized manually. You can set the device time manually or check **Sync. with Computer Time** to synchronize the device time with the computer's time.

## 17.4 Set DST on PC Web

### Steps

1. Click **Configuration** → **System** → **System Settings** → **Time Settings** .
2. Enable **DST**.
3. Set the DST start time, end time and bias time.
4. Click **Save** to save the settings.

## Chapter 18 Audio Settings

You can set audio parameters on PC Web and mobile Web.

- [Set Audio Parameters on Mobile Web](#)
- [Set Audio Parameters on PC Web](#)

### 18.1 Set Audio Parameters on Mobile Web

You can set the input volume and output volume.

Tap  → **Audio** to enter the settings page.

Set the input volume and output volume.

### 18.2 Set Audio Parameters on PC Web

#### Steps

1. Click **Configuration** → **Video/Audio** → **Audio** .
2. Select the audio encoding type.
3. Set the input and output volume.

## Chapter 19 Image Settings

- [Set Image Parameters on Mobile Web](#)
- [Set Image Parameters on PC Web](#)
- [Set OSD \(On-Screen Display\) on PC Web](#)
- [Crop Target on PC Web](#)

### 19.1 Set Image Parameters on Mobile Web

You can enable WDR.

Tap  → **Image** to enter the settings page.

Tap to enable the function of **WDR**.



WDR is used when there is a high contrast of the bright area and the dark area of the scene.

---

### 19.2 Set Image Parameters on PC Web

You can adjust the image parameters, video parameters, backlight parameters and Day/Night Switch.

#### Steps

1. Click **Configuration** → **Image** → **Display Settings** .
2. Configure the parameters to adjust the image.

#### Image Adjustment

Drag the block or enter the value to adjust the live video's brightness, contrast, saturation, and sharpness.

#### Backlight

You can click to **Enable BLC** or enable **WDR**.



- BLC compensates light to the object.
  - WDR is used when there is a high contrast of the bright area and the dark area of the scene.
  - These two functions cannot be enabled at the same time.
- 

#### Day/Night Switch

Select the day/night switch mode to **Daytime**, **Night**, **Auto** or **Scheduled-Switch**.

### Auto

The camera switches between the day mode and the night mode according to the illumination automatically.

The sensitivity ranges from 0 to 7, and the higher sensitivity results in the more easily to trigger the mode switch.

The switch time refers to the interval time between the day/night switch. You can set it from 5 sec to 120 sec.

### Scheduled-Switch

The camera switches the day mode and the night mode according to the start time and end time you set.

### Video Standard

Set the video frame rate when performing live view remotely. After changing the standard, you should reboot the device to take effect.

#### PAL

25 frames per second. Suitable for mainland China, Hong Kong (China), the Middle East countries, Europe countries, etc.

#### NTSC

30 frames per second. Suitable for the USA, Canada, Japan, Taiwan (China), Korea, the Philippines, etc.

3. Click **Restore Default Settings** to restore the parameters to the default settings.

## 19.3 Set OSD (On-Screen Display) on PC Web

You can customize the camera name, time/date format, display mode, and OSD size displayed on the live view.

### Steps

1. Click **Configuration** → **Image** → **OSD Configuration** to enter the settings page.
2. Check the corresponding checkbox to select the display of camera name, date or week if required.
  - Select **Display Name**: Edit the **Camera Name**.
  - Select **Display Date**: Select from the drop-down list to set the **Time Format** and **Date Format**.
3. Drag to adjust the OSD position and alignment.
4. Click **Save** to enable the settings.

## 19.4 Crop Target on PC Web

You can select a target and crop images on the live view.

### Steps

1. Click **Configuration** → **Image** → **Target Cropping** .
2. Check **Enable** to enable the function.
3. Select **Cropping Resolution**.
4. Click **Save**.



### Note

- You can select **Cropping Resolution** as **704\*576**, **1280\*720**, or **1920\*1080**.
  - You can zoom in or zoom out the image by selecting **Cropping Resolution** after clicking **Save**.
-

## Chapter 20 Motion Detection Settings

You can set motion detection parameters on PC Web and Mobile Web.

- [Set Motion Detection on PC Web](#)
- [Set Motion Detection on Mobile Web](#)

### 20.1 Set Motion Detection on Mobile Web

After enable the function of motion detection, people or stuff enter the configured area will trigger alarm.

#### Steps

1. Tap  → **Image** to enter the image setting page.
2. Tap to enable **Motion**.
3. Tap **Save** to save the setting.

#### Result

After enable the function of motion, people or stuff enter the configured area will trigger alarm.

### 20.2 Set Motion Detection on PC Web

After enable the function of motion detection, people or stuff enter the configured area will trigger alarm.

#### Steps

1. Click **Configuration** → **Event** → **Event Detection** → **Motion** .
2. Enable **Motion**.
3. Drag the process bar to adjust the **Sensitivity** parameter.
4. Click **Save**.



#### Note

The arming schedule is defaulted as all-day.

---

## Chapter 21 Access Control Settings

You can set access control parameters.

- [Set Door Parameters on PC Web](#)
- [Set Door Parameters on Mobile Web](#)
- [Set Public Password on PC Web](#)
- [Set Public Password on Mobile Web](#)
- [Set I/O Parameters on PC Web](#)
- [Set I/O Parameters on Mobile Web](#)

### 21.1 Set Door Parameters on Mobile Web

You can set door name and check open duration.

Tap **Configuration** → **Access Control** → **Door Parameters** .

Tap **Save** to save the settings after the configuration.

#### Name

You can create a name for the door.

#### Open Duration

You can check the unlocking duration of the door.



#### Note

The Open Duration is 3 by default.

---

### 21.2 Set Public Password on Mobile Web

After setting the public password, you can open the door via the public password.

#### Steps

1. Tap **Configuration** → **Access Control** → **Password Settings** .
2. Tap **+** to add public password.
  - 1) Enter the password and confirm the password.
  - 2) **Optional:** Add remarks for the password.
  - 3) Select Electric Lock.
3. Tap **Save** to save the settings.

### 21.3 Set I/O Parameters on Mobile Web

You can set I/O Parameters on mobile Web.

### Steps

1. Tap **Configuration** → **Access Control** → **I/O Settings** .
2. Select Input 2 as Disable or Unlock.



The Input 1 is Unlock by default.

3. Select Output 2 as Disable or Electric Lock.



The Output 1 is Electric Lock by default.

---

## 21.4 Set Door Parameters on PC Web

You can set door name and check open duration.

Click **Configuration** → **Access Control** → **Door Parameters** .

Select a door and set the **Door Name**.

Click **Save** to save the settings after the configuration.

## 21.5 Set Public Password on PC Web

After setting the public password, you can open the door via the public password.

### Steps

1. Click **Configuration** → **Access Control** → **Password Settings** .
2. Click **Add** to add public password.
  - 1) Select **Password Type**.
  - 2) Enter the password and confirm the password.
  - 3) **Optional**: Add remarks for the password.
  - 4) Select Electric Lock.
3. Click **Save** to save the settings.

## 21.6 Set I/O Parameters on PC Web

You can set I/O Parameters on PC Web.

### Steps

1. Click **Configuration** → **Access Control** → **Door Parameters** .
2. Select Input 2 as Disable or Unlock.



The Input 1 is Unlock by default.

---

3. Select Output 2 as Disable or Electric Lock.

---

 **Note**

The Output 1 is Electric Lock by default.

---

## Chapter 22 Video Intercom Settings

You can set video intercom parameters.

- [Set Call Parameters on PC Web](#)
- [Set Call Parameters on Mobile Web](#)
- [Set Ringtone on PC Web](#)
- [Press Button to Call on PC Web](#)
- [Press Button to Call on Mobile Web](#)
- [Set Sub Module on PC Web](#)
- [Set Sub Module on Mobile Web](#)

### 22.1 Set Call Parameters on Mobile Web

Set the Max. call duration.

Tap  → **Intercom** → **Call Setting** .

Set **Max. Communication Time**. Press **Save**.





The Max. communication time range is 15 s to 90 s.

---

### 22.2 Press Button to Call on Mobile Web

#### Steps

1. Tap  → **Intercom** → **Press Button to Call** .
2. Tap to select a button to configure.
3. Enable the function of **Press Button to Call** and set **Room No.** for this button.
4. Tap **Save**.
5. Press  in the upper-right corner, to set backlight mode and view button image.



- You can check the order of connected sub modules and button No. of each module.
  - If you set the backlight mode as custom, you should then set the **Start Time** and **End Time**.
- 

#### Result

After configuration, you can press the button to call the corresponding indoor station.

## 22.3 Set Sub Module on Mobile Web

You can configure the sub modules on mobile Web.

### Steps

1. Tap  → **Intercom** → **Sub Module Configuration** .
2. View the version and online status of connected modules.
3. **Optional:** For **Display Module**, you can drag the block to adjust the brightness and tap to enable **Buzzer**.

## 22.4 Set Ringtone on PC Web

### Steps

1. Click **Configuration** → **Intercom** → **Ringbacktone Settings** to enter the settings page.
2. Slide to **Enable Ringtone**. After enabled, you can import new ringtones from local.
3. Click  to import new ringtones.



The supported audio file type for importing is .wav. The file should be less than 800 KB.

---

## 22.5 Set Call Parameters on PC Web

Set the Max. call duration.

Go to **Configuration** → **Intercom** → **Call Settings** .

Drag the block to set the **Max. Communication Time** . Click **Save**.



The Max. communication time range is 15 s to 90 s.

---

## 22.6 Press Button to Call on PC Web

You can set room No. of call button, view button image and set backlight.

### Steps

1. Click **Configuration** → **Intercom** → **Press Button to Call** to enter the settings page.
2. Set room No. of each button and click to enable **Press Button to Call**, you can then press the correspondent button to call the specific indoor station.



The room No. refers to the mapping room No. which you can custom the No. on your own.

---

- 3. Optional:** Click **Backlight Settings** to set backlight mode as Open, Disable, Auto or Custom. Click **Save** to save the settings.

---

 **Note**

If you set the backlight mode as custom, you should then set the **Start Time** and **End Time**.

- 4.** Click **View Button Image** and you can check the order of connected sub modules and button No. of each module.
- 5.** Click **Save**.

## 22.7 Set Sub Module on PC Web

You can configure the sub modules on PC Web.

### Steps

- 1.** Click **Configuration** → **Intercom** → **Sub Module Configuration** to enter the settings page.
- 2.** Click **Operation** to set sub module parameters.
  - 1) Drag the block or enter the value of brightness.
  - 2) Click to enable **Buzzer**.
  - 3) Select the default home page of the sub module.
  - 4) Add a call button. Click **Add**. Enter the **name** and **call** and click **OK** to save the settings.

## Chapter 23 Card Settings

### 23.1 Set Card Security

Tap  → **Access Control** → **Card Security** to enter the configuration page.

Set the parameters and tap **Save**.

#### **Enable DESFire Card**

The device can read the data from DESFire card when enabling the DESFire card function.

#### **DESFire Card Read Content**

After enable the DESFire card content reading function, the device can read the DESFire card No.

### 23.2 Set Card Security on PC Web

Click **Configuration** → **Card Settings** → **Card Type** to enter the settings page.

Set the parameters and click **Save**.

#### **Enable DESFire Card**

The device can read the data from DESFire card when enabling the DESFire card function.

#### **DESFire Card Read Content**

After enable the DESFire card content reading function, the device can read the DESFire card No.

## Chapter 24 Set Fingerprint Security Level

### 24.1 Set Fingerprint Security Level on PC Web

Click **Configuration** → **Smart** → **Smart** .

#### **Fingerprint Security Level**

Select the fingerprint security level.

The higher is the security level, the lower is the false acceptance rate (FAR).

The higher is the security level, the higher is the false rejection rate (FRR).

### 24.2 Set Fingerprint Security Level on Mobile Web

Set fingerprint security level.

Tap  → **Smart** → **Fingerprint Parameters** .

#### **Fingerprint Security Level**

Select the fingerprint security level.

The higher is the security level, the lower is the false acceptance rate (FAR).

The higher is the security level, the higher is the false rejection rate (FRR).

## Chapter 25 Upgrade and Maintenance

- [Upgrade and Maintenance on PC Web](#)
- [Upgrade and Maintenance on Mobile Web](#)

### 25.1 Upgrade and Maintenance on Mobile Web

Restart device and restore device parameters.

#### Restart Device

Tap  → **Restart** .

Tap **Restart** to restart the device.

#### Restore Parameters

Tap  → **Default** .

#### Restore to Default Settings

The device will restore to the default settings, except for the user information.

#### Restore to Factory Settings

All parameters will be restored to the factory settings. You should activate the device before usage.

#### Log Export

Tap  → **Log Export** .

Tap **Export** to export the maintenance log.

### 25.2 Upgrade and Maintenance on PC Web

Reboot device, restore device parameters, and upgrade device version.

#### Reboot Device

Click **Maintenance and Security** → **Maintenance** → **Restart** .

Click **Restart** to reboot the device.

#### Upgrade

Click **Maintenance and Security** → **Maintenance** → **Upgrade** .

Select an upgrade type from the drop-down list. Click  and select the upgrade file from your local PC. Click **Upgrade** to start upgrading.

If the device has been connected to Hik-Connect and network, when there is a new installation package in Hik-Connect, you can click **Upgrade** after Online Update to upgrade the device system.

---

## Note

Do not power off during the upgrading.

---

## Restore Parameters

Click **Maintenance and Security** → **Maintenance** → **Backup and Reset** .

### Restore All

All parameters will be restored to the factory settings. You should activate the device before usage.

### Restore

The device will restore to the default settings, except for the user information.

## Import and Export Parameters

Click **Maintenance and Security** → **Maintenance** → **Backup and Reset** .

### Device Parameters

#### Export

Click **Export** to export the device parameters.

---

## Note

You can import the exported device parameters to another device.

---

#### Import

Click  and select the file to import. Click **Import** to start import configuration file.

### Data Migration

#### Export

Click **Export** to migrate user information and configuration details of the device to other devices.

---

## Note

You can migrate user information and configuration details of the device to other devices. The information and data may include door station configuration data, personal information, card information, advertisement information and etc.

---

#### Import

Click  and select the file to import. Click **Import** to start import configuration file.

---

## Note

You can import migrated user data and configuration details of other devices to this device.

---

## Chapter 26 Change Activation/Admin Password

You can change activation/admin password on PC and Mobile Web.

- [Change Administrator's Password on PC Web](#)
- [Change Administrator's Password on Mobile Web](#)

### 26.1 Change Administrator's Password on Mobile Web

#### Steps

1. Tap  → **User Management** → **User Management** → **admin** to enter the setting page.
2. Enter the old password and create a new password.
3. Confirm the new password.
4. Tap **Save**.



#### Caution

- The password should be 8 to 16 characters.
  - The password should contain at least 2 of the following types: digits, lowercase letters, uppercase letters and special characters.
  - Do not contain following characters in the password: the user name, 123, admin (case-insensitive), 4 or more continuously increasing or decreasing digits, or 4 or more consecutively repeated characters.
  - The password strength of the device can be automatically checked. In order to increase the security of your product, we highly recommend you change the password of your own choosing. And we recommend you change your password regularly, especially in the high security system, changing the password monthly or weekly can better protect your product. Proper configuration of all passwords and other security settings is the responsibility of the service provider and/or end-user.
  - (If the device supports AP mode, after the admin password is changed, the password of AP hotspot will be changed simultaneously.)
- 

### 26.2 Change Administrator's Password on PC Web

#### Steps

1. Click **Configuration** → **System** → **User Management** .
2. Click  .
3. Enter the old password and create a new password.
4. Confirm the new password.
5. Click **Save**.



### **Caution**

- The password should be 8 to 16 characters.
  - The password should contain at least 2 of the following types: digits, lowercase letters, uppercase letters and special characters.
  - Do not contain following characters in the password: the user name, 123, admin (case-insensitive), 4 or more continuously increasing or decreasing digits, or 4 or more consecutively repeated characters.
  - The password strength of the device can be automatically checked. In order to increase the security of your product, we highly recommend you change the password of your own choosing. And we recommend you change your password regularly, especially in the high security system, changing the password monthly or weekly can better protect your product. Proper configuration of all passwords and other security settings is the responsibility of the service provider and/or end-user.
  - (If the device supports AP mode, after the admin password is changed, the password of AP hotspot will be changed simultaneously.)
-

## Chapter 27 Account Security Settings

You can set account security on PC Web and Mobile Web.

- [Set Account Security on PC Web](#)
- [Set Account Security on Mobile Web](#)

### 27.1 Set Account Security on Mobile Web

You can change the security questions and answers, or the email address on Mobile Web. After change the settings, once you forgot the device password, you should answer the new questions or use the new email address to reset the device password.

#### Steps

1. Tap  → **User Management** → **User Management** → ... → **Account Security Settings** .
2. Change the security questions or email address according your actual needs.
3. Enter the device password and tap **Save** to confirm changing.

### 27.2 Set Account Security on PC Web

You can change the security questions and answers, or the email address on PC Web. After change the settings, once you forgot the device password, you should answer the new questions or use the new email address to reset the device password.

#### Steps

1. Click **Configuration** → **System** → **User Management** → **Account Security Settings** .
2. Change the security questions or email address according your actual needs.
3. Enter the device password and click **OK** to confirm changing.

## Chapter 28 View Device Arming/Disarming Information on PC Web

View device arming type and arming IP address.

Go to **Configuration** → **User Management** → **Arming/Disarming Information** .

You can view the device arming/disarming information. Click **Refresh** to refresh the page.

## Chapter 29 View Online Users on PC Web

The information of users logging into the device is shown.

Go to **Configuration** → **User Management** → **Online Users** to view the list of online users.

## Chapter 30 Set Notice Publication on PC Web

You can set the notice publication for the device.

Click **Configuration** → **Preference** → **Notice Publication** .

---

### **Note**

The device needs to connect to a touch display module first.

---

### **Theme Management**

Click **Media Library Management** → + to upload the picture from the local PC.

---

### **Note**

Only the format of JPG is supported. Each picture should be smaller than 1 MB. Up to 5 pictures are supported.

---

You can click **+Add Program**, and set **Name** to create a theme. After creating the theme, click + in the **Theme Management** panel to select pictures in the media library. Click **OK** to add pictures to the theme.

### **Set Slide Show Interval**

Drag the block or enter the number to set the slide show interval. The picture will be changed according to the interval.

---

### **Note**

The slide show interval ranges from 1 s to 120 s.

---

### **Customized Text Display**

Click to enable customized text display and enter the custom content. After the setting, the customized text will be displayed.

## Chapter 31 Device Debugging on PC Web

You can set device debugging parameters.

### Steps

1. Click **Maintenance and Security** → **Maintenance** → **Device Debugging** .
2. You can set the following parameters.

#### Enable SSH

To raise network security, disable SSH service. The configuration is only used to debug the device for the professionals.

#### Print Log

You can click **Export** to export log.

#### Capture Network Packet

You can set the **Capture Packet Duration**, **Capture Packet Size**, and click **Start** to capture.

## Chapter 32 View Online Document

You can view online help document via PC Web and Mobile Web.

- [\*View Online Document on PC Web\*](#)
- [\*View Online Document on Mobile Web\*](#)

### 32.1 View Online Document on Mobile Web

Tap  → **View Online Document** . Tap **View Online Document**, you can scan the QR code with your mobile phone for details.

### 32.2 View Online Document on PC Web

On the main page of the device PC Web, click  → **Online Document** , to view the help document.

## Chapter 33 View Open Source Software License

You can view Open Source Software License via PC Web and Mobile Web.

- [\*View Open Source Software License on PC Web\*](#)
- [\*View Open Source Software License on Mobile Web\*](#)

### 33.1 View Open Source Software License on Mobile Web

Tap  → **Open Source Software Licenses** to view the device license.

### 33.2 View Open Source Software License on PC Web

On the main page of the device PC Web, click  → **Open Source Software Statement** , to view the device license.

## Chapter 34 Quick Operation via Web Browser

### 34.1 Change Password Type

If you forget the device activation password, you can change the password via security questions and E-mail. Set the security questions before configuration.

Click  on the top right of the web page to enter the **Change Password** page.

#### Security Question Verification

Answer the security questions.

#### E-mail Verification

1. Export the QR code and send it to ***pw\_recovery@hikvision.com*** as attachment.
2. You will receive a verification code within 5 minutes in your reserved email.
3. Enter the verification code into the verification code field to verify your identification.

Click **Next**. Or you can click **Skip** to skip the step.

### 34.2 Select Language

You can select a language for the device system.

Click  in the top right of the web page to enter the wizard page.

Click **Next** on the change password page. You can select a language for the device system from the drop-down list.

By default, the system language is English.



#### Note

After you change the system language, the device will reboot automatically.

---

Click **Next** to complete the settings.

### 34.3 Time Settings

Click  on the top right of the web page to enter the wizard page. After previous settings, you can click **Next** to enter the **Time Settings** page.

#### Time Zone

Select the device located time zone from the drop-down list.

#### Time Sync.

**Manual**

You can set the device time manually or click **Sync. with Computer Time** to synchronize the device time with the computer's time.

### DST

You can set the DST start time, end time and bias time.

Click **Next** to save the settings and go to the next parameter. Or click **Skip** to skip time settings.

## 34.4 Administrator Settings

### Steps

1. Click  on the top right of the web page to enter the wizard page. After previous settings, you can click **Next** to enter the **Administrator Settings** page.
2. Enter the employee ID and name of the administrator.
3. Add card. Click **+** to enter the Card No. or click **read** to present the card on the card reading area to read the card No. automatically.



### Note

Up to 5 cards can be supported.

---

4. Click **Next** .

## 34.5 Link Video Intercom Devices

You can link to indoor station and set DIP switch.

### Steps

1. Click  on the top right of the web page to enter the wizard page. After previous settings, you can click **Next** to enter the **Link Video Intercom Devices** page.
2. Hold the button on the right side of the device for 10 s to trigger the function of device linkage.



### Note

The **IN USE** indicator will be normally on.

---

3. Make sure the DIP switch is correct.
4. Click **Complete** .



See Far, Go Further